

# SHELVING



# Camshelving®



Easy and Quick to Clean



Easy to Adjust and Configure



Unquestionably Strong,  
Durable and Stable



Rust Free

**CAMGUARD**  
ANTIMICROBIAL SHELF PLATES



Store and Transport  
Food Safely



**COMPONENTS**

Listed by the National Sanitation  
Foundation. NSF, an independent  
testing organization, lists  
products which meet their criteria  
for sanitation and cleanability



Dishwasher Safe  
Except mobile parts



Fit for Food  
Products



Cadmium-Free



Recyclable  
Polypropylene

Consultant Cut  
Sheets and CAD  
drawings are  
available on  
[www.cambro.com](http://www.cambro.com),  
KCL or AutoQuotes

Camshelving is covered by EU Patent #0686817 A2.

# Easy And Quick To Clean

## For a Sanitary Storage Area

- Shelf plates are easy to remove and run through the dishwasher.
- Smooth polypropylene surface quickly wipes clean.
- Spills clean quickly and easily, reducing the risk of cross-contamination.
- Camshelving® is weldless, so liquids and dirt cannot get inside crevices.



Shelf plates can be placed in an open end Camrack® OETR314 and washed in a commercial dishwasher.



- A silver-ion technology that inhibits the growth of mold, fungus and bacteria.
- Camguard works continuously to suppress the growth of microbes between cleanings.
- All shelf plates are embedded with Camguard antimicrobial so it will not scrape off, wash off or wear out.



# Strong And Durable

## Strong as Steel

- Posts and traverses are the weight bearing components, constructed with a steel core and encapsulated by a thick polypropylene outer layer.
- Inner steel core ensures that Camshelving is strong, durable and stable.

- Thick, polypropylene outer layer will not chip, break or corrode.
- Post connectors provide exceptional cross stabilization.



Weight bearing components are made with a steel core.



	<b>SINGLE UNIT - 4 Shelves</b>	<b>SINGLE UNIT - 4 Shelves</b>	<b>DUNNAGE STAND</b>	<b>CORNER UNIT (Attached Unit)</b>	<b>MOBILE UNIT</b>
<b>TRAVERSE LENGTH</b>	24" to 48" (610 mm to 1220 mm)	54" to 72" (1380 mm to 1830 mm)	54" to 72" (1380 mm to 1830 mm)	24" to 48" (610 mm to 1220 mm)	24" to 48" (610 mm to 1220 mm)
<b>WEIGHT BEARING CAPACITY PER SHELF</b>	800 lbs. (363 Kg)	600 lbs. (272 Kg)	1000 lbs. (454 Kg)	400 lbs. (181 Kg)	—
<b>WEIGHT BEARING CAPACITY PER UNIT</b>	3200 lbs. (1451 Kg)	2400 lbs. (1089 Kg)	—	1600 lbs. (726 Kg)	750 lbs. (340 Kg)

Dunnage Stands are used only on the bottom shelf. Recommended for traverses 54" (1380 mm) or longer.

Corner Connectors are recommended for use on traverses 48" (1220 mm) or less.

Due to the weight bearing capacity of casters, maximum weight load on an entire Mobile Camshelving Unit is 750 lbs. (340 Kg).

# Easy To Assemble & Adjust

## Build Any Configuration and Fit Any Size Area

- Create a space efficient layout for any area.
- Assembles in minutes, requiring only the use of a mallet.
- Shelves can be adjusted in 4" (100 mm) increments without disassembling the entire unit.
- Two units can be connected together with shelves at alternating heights for maximum storage flexibility.
- Corner Connectors attach units to create a 90° angle or U shape.

POST HEIGHT	DOVETAIL INCREMENT	NUMBER OF POSITIONS PER POST
<b>Stationary</b>		
32" (820 mm)	4" (100 mm)	6
56" (1430 mm)	4" (100 mm)	12
64" (1630 mm)	4" (100 mm)	14
72" (1830 mm)	4" (100 mm)	16
84" (2140 mm)	4" (100 mm)	19
<b>Mobile</b>		
35" (890 mm)	4" (100 mm)	6
59" (1500 mm)	4" (100 mm)	12
67" (1700 mm)	4" (100 mm)	14
75" (1910 mm)	4" (100 mm)	16

### EASY TO ADJUST!

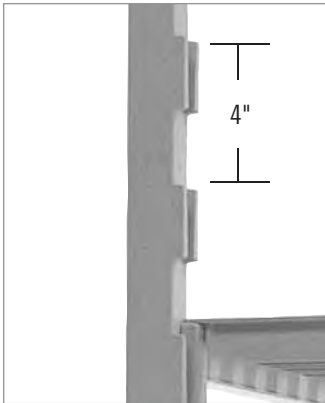

Shelves can be adjusted in 4" (100 mm) increments, without disassembling the unit.

### EASY TO ASSEMBLE!



Traverses slide easily down onto dovetail.

# Rust Free

## For Use in Any Area, Wet or Dry

- Camshelving is weldless with no exposed metal, so it remains rust free.
- Safe to -36°F (-38°C), making Camshelving the ideal shelving system for freezers, walk-ins or any wet or humid environment.
- Not even salt water or sea air will corrode Camshelving.



Lifetime limited warranty against rust and corrosion for traverses and stationary posts.



Dry Storage Room



Cold Storage Room

# Free Camshelving® Consulting



**Cambro provides a free consulting service to maximize your storage area. No cost or obligation.**

1. Simply provide the dimensions of the storage space, number of shelves per unit, height of the posts, and any additional requirements you have.

2. Cambro will provide a recommended floor plan and product order list.
3. Your Cambro distributor or sales representative will contact you with pricing.

4. To contact the Camshelving Consulting Department, please call 1-714-230-4113, Fax 1-714-230-4199 or email [mperez@cambro.com](mailto:mperez@cambro.com).

# Components

Camshelving® is a modular system that allows the flexibility to assemble shelving to fit any size area. The key components, including posts, post connectors, traverses and shelf plates, are available in a variety of

sizes. They can be easily configured to custom build shelving to maximize storage space. Unique design elements such as shared posts and corner connectors simplify assembly and increase storage capacity.

## Traverses

Traverses have a steel core with a polypropylene exterior to provide strength and durability.

Traverses connect to the post by sliding on to the dovetail on the post.

Two traverses are needed to build one shelf, and they define the length of the unit.

## Shelf Plates

Shelf Plates are made of polypropylene. Dishwasher safe.

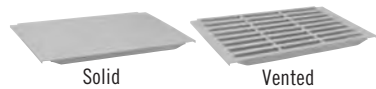

Solid

Vented

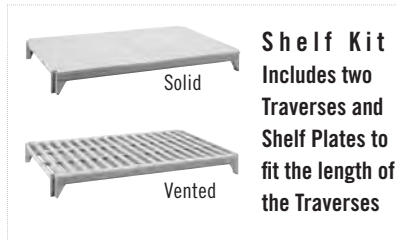

**Shelf Kit**  
Includes two Traverses and Shelf Plates to fit the length of the Traverses

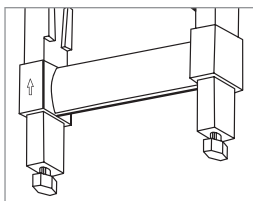

## Posts For Stationary Unit

Posts have a steel core with a polypropylene exterior to provide strength and durability.

Posts define the height of the shelving unit and are measured with the leveling foot fully engaged.

Post for Stationary Unit



Stationary Unit

## Post Connectors

Post connectors hold two posts together and define the width of the unit.

They are made of polypropylene and provide excellent cross stabilization.

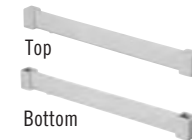

Top

Bottom



**Post Kit**  
Includes two Posts and a set of one top and one bottom Post Connector

## Posts For Mobile Camshelving

Mobile Camshelving posts must be used to build mobile Camshelving units.



Mobile Unit



## Castors

Available in standard for dry storage or premium for freezers, cold, or wet applications.

# Maximize Space Utilization

Camshelving® is available in starter and add-on units for ease of ordering and assembly.

## Starter Units

- Available in stationary or mobile units.
- Starter units ship complete with two post kits, traverses and shelf plates to build an entire unit.

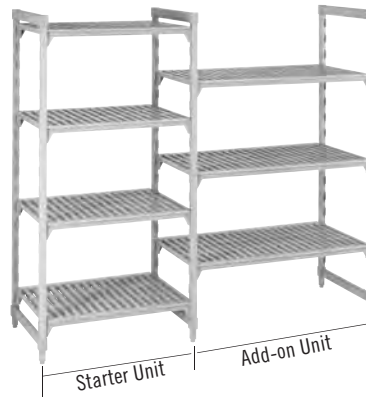

## Add-On Units

- Add-On units ship complete with one post kit, traverses and shelf plates to attach to an adjoining unit.
- The traverses on both the first and second unit share the middle post.
- No add-on clips or S-hooks required.
- There is no loss of weight bearing capacity when built in a straight line.

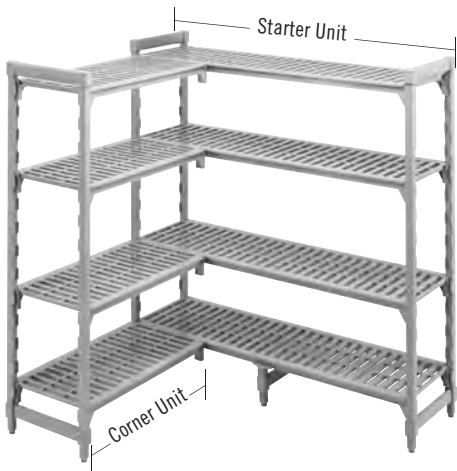

## Corner Units & U-Shape Units

- Corner connectors can be used to build corner units and U Shape units.
- Traverses snap onto corner connectors just like they snap onto the dovetails of the posts.

## Corner Connector Set

- Attaches a basic unit to a second unit at a 90° angle or to form a U-shape.
- A set of corner connectors are needed for each shelf.



\* Corner connectors are recommended for use on traverses equal to or shorter than 48" (1220 mm), and covered by U.S. Patent D498,664S.

## Dunnage Stand

- Increases weight bearing capacity to 1000 lbs. (454 Kg) on the bottom shelf.
- Recommended for units 54" (1380 mm) or longer.



\* Dunnage stands are covered by U.S. Patent US 6,981,454B2.

## Fence System

- Prevents stored items from falling off shelving units.
- Ideal for mobile shelving.

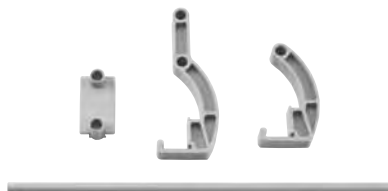

## Mobile Units

- Mobile Camshelving units are built by using posts for mobile carts and inserting casters.
- Mobile units are not designed to serve as transport carts.
- Casters sold separately.



Mobile unit shown with optional fencing.

## Seismic Foot

- Bolts a post to the floor for a more stable base.



## Wall Fastener

- Fastens a unit to a wall as a safety precaution.
- Screws not included.



## Identification Tag

- Easily clips onto traverses to identify stored items.
- Made of PVC.
- Includes 12 HACCP labels.



## Donut Bumper

- Protects mobile Camshelving.
- 3/2" (90 mm) Bumper.



# Camshelving® Configuration Details

- The following charts are provided to assist in developing a footprint for your storage area.
- They can also be used to help determine your actual shelf space.
- Traverse measurements are based on outside, or overall unit length.
- This includes the posts.
- The overall length varies slightly when using a basic unit, add-on unit, intermediate unit or corner unit.
- These variations are outlined below.

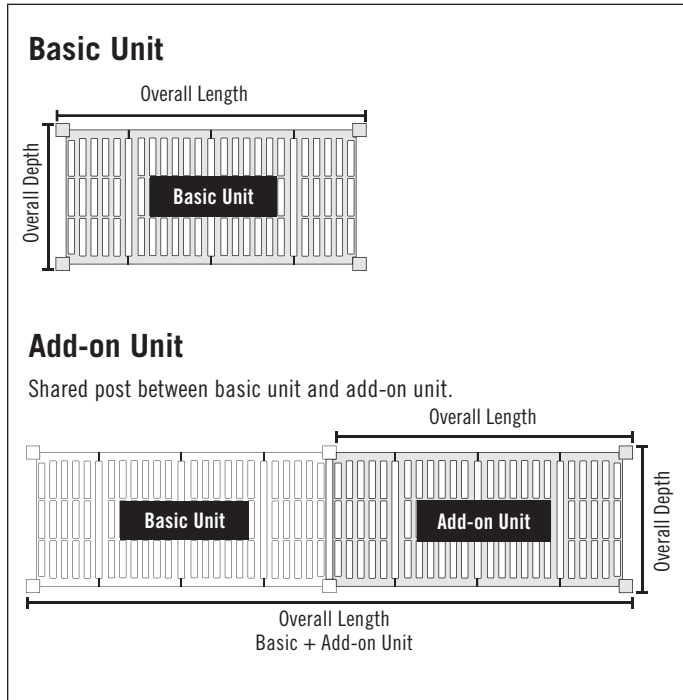

UNIT	BASIC UNIT OVERALL LENGTH	ADD-ON UNIT OVERALL LENGTH	BASIC + ADD-ON UNIT OVERALL LENGTH
<b>24"</b> (610 mm)	24" (610 mm)	22¼" (565 mm)	46¼" (1175 mm)
<b>30"</b> (760 mm)	30" (760 mm)	28¼" (720 mm)	58¼" (1480 mm)
<b>36"</b> (910 mm)	36" (910 mm)	34¼" (870 mm)	70¼" (1780 mm)
<b>42"</b> (1070 mm)	42" (1070 mm)	40¼" (1025 mm)	82¼" (2095 mm)
<b>48"</b> (1220 mm)	48" (1220 mm)	46¼" (1175 mm)	94¼" (2395 mm)
<b>54"</b> (1380 mm)	54" (1380 mm)	52¼" (1330 mm)	106¼" (2710 mm)
<b>60"</b> (1530 mm)	60" (1530 mm)	58¼" (1480 mm)	118¼" (3010 mm)
<b>72"</b> (1830 mm)	72" (1830 mm)	70¼" (1790 mm)	142¼" (3620 mm)

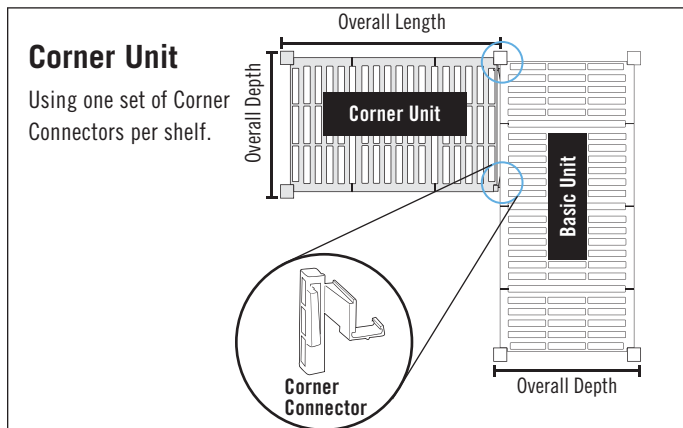

UNIT	CORNER UNIT OVERALL LENGTH	INTERMEDIATE UNIT OVERALL LENGTH
<b>24"</b> (610 mm)	23" (585 mm)	22" (560 mm)
<b>30"</b> (760 mm)	29" (740 mm)	28" (715 mm)
<b>36"</b> (910 mm)	35" (890 mm)	34" (865 mm)
<b>42"</b> (1070 mm)	41" (1045 mm)	40" (1020 mm)
<b>48"</b> (1220 mm)	47" (1195 mm)	46" (1170 mm)

Corner Connectors are recommended for use on traverses 48" (1220 mm) or less.

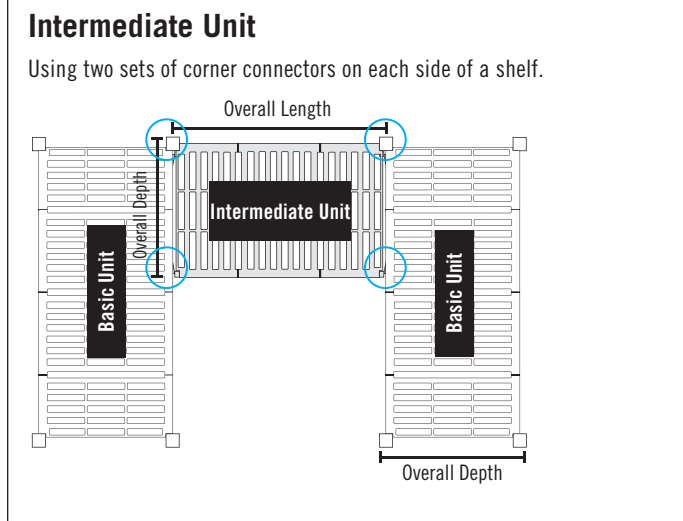



## Shelf Spacing

Dovetails are spaced every 4" (100 mm)

POST HEIGHT	NUMBER OF POSITIONS PER POST	POST HEIGHT	NUMBER OF POSITIONS PER POST
<b>Stationary</b>		<b>Mobile</b>	
32" (820 mm)	6	35" (890 mm)	6
56" (1430 mm)	12	59" (1500 mm)	12
64" (1630 mm)	14	67" (1700 mm)	14
72" (1830 mm)	16	75" (1910 mm)	16
84" (2140 mm)	19		

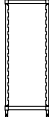
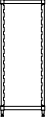
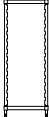

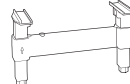
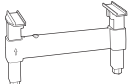
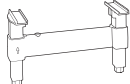
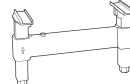

# Stationary Post Kits and Accessories

Stationary Post Kits					
HEIGHT	WIDTH	<b>14"</b> 360 mm	<b>18"</b> 460 mm	<b>21"</b> 540 mm	<b>24"</b> 610 mm
<b>32"</b> 820 mm	CODE	CSPK1432	CSPK1832	CSPK2132	CSPK2432
	CASE LBS. (CUBE)	8.6 (0.30)	8.91 (0.32)	9.2 (0.31)	9.69 (0.3)
	CASE KG/CUBE M <sup>3</sup>	3,9 (0,01)	4,04 (0,01)	4,17 (0,01)	4,4 (0,01 0,01)
<b>56"</b> 1430 mm	CODE	CSPK1456	CSPK1856	CSPK2156	CSPK2456
	CASE LBS. (CUBE)	13.18 (0.47)	13.49 (0.47)	13.78 (0.47)	14.27 (0.47)
	CASE KG/CUBE M <sup>3</sup>	5,98 (0,01)	6,12 (0,01)	6,25 (0,01)	6,47 (0,01)
<b>64"</b> 1630 mm	CODE	CSPK1464	CSPK1864	CSPK2164	CSPK2464
	CASE LBS. (CUBE)	14.77 (0.46)	15.07 (0.46)	15.37 (0.46)	15.86 (0.46)
	CASE KG/CUBE M <sup>3</sup>	6,7 (0,01)	6,84 (0,01)	6,97 (0,01)	7,19 (0,01)
<b>72"</b> 1830 mm	CODE	CSPK1472	CSPK1872	CSPK2172	CSPK2472
	CASE LBS. (CUBE)	16.73 (0.52)	17.04 (0.52)	17.33 (0.52)	17.82 (0.52)
	CASE KG/CUBE M <sup>3</sup>	7,59 (0,01)	7,73 (0,01)	7,86 (0,01)	8,08 (0,01)
<b>84"</b> 2140 mm	CODE	CSPK1484	CSPK1884	CSPK2184	CSPK2484
	CASE LBS. (CUBE)	19 (0.61)	19.3 (0.61)	19.59 (0.61)	20.08 (0.61)
	CASE KG/CUBE M <sup>3</sup>	8,62 (0,02)	8,75 (0,02)	8,89 (0,02)	9,11 (0,02)

Case Pack: 1      Color: Speckled Gray (480).

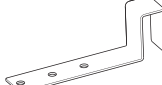

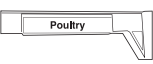





Dunnage Stands					
HEIGHT	WIDTH	<b>14"</b> 360 mm	<b>18"</b> 460 mm	<b>21"</b> 540 mm	<b>24"</b> 610 mm
<b>6½"</b> 165 mm	CODE	CSDS14	CSDS18	CSDS21	CSDS24
	CASE LBS. (CUBE)	2.6 (0.18)	2.9 (0.22)	3.1 (0.26)	3.3 (0.30)
	CASE KG (CUBE M <sup>3</sup> )	1,2 (0,0050)	1,3 (0,0062)	1,4 (0,0074)	1,5 (0,0085)

Case Pack: 1      Color: Speckled Gray (480).

Accessories						
		<b>Seismic Foot</b>	<b>Wall Fastener</b>	<b>Corner Connectors</b>	<b>Id Tag 6"</b>	<b>Id Tag 3"</b>
	CODE	CSEQ3	CSWF	CSCC	CSID	CSID3
	DESCRIPTION	Seismic Foot	Wall Fastener	90° Left & Right	6" ID Tag	3" ID Tag
	COLOR	Silver	Silver	Speckled Gray (480)	White/Clear	White/Clear
	SIZE: L x W x H	4" x 3¼" x 2½" (100 x 85 x 60 mm)	9¾" x 1½" x 2½" (238 x 48 x 73 mm)	—	1" x 6" (25 x 150 mm)	1" x 3" (25 x 80 mm)
	CASE LBS. (CUBE)	1.43 (0.04)	4.08 (0.27)	0.38 (0.05)	0.82 (0.08)	0.58 (0.06)
	CASE KG (CUBE M <sup>3</sup> )	0,017 (0,011)	1,85 (0,0006)	0,017 (0,014)	0,35 (0,0079)	0,35 (0,0079)
	CASE PACK	4 each	4 each	1 set of 2 parts	12 each	12 each











# Solid Shelf Kits

									
WIDTH	LENGTH	24"	30"	36"	42"	48"	54"	60"	72"
		610 mm	760 mm	910 mm	1070 mm	1220 mm	1380 mm	1530 mm	1830 mm
14" 360 mm	CODE	CS1424SK	CS1430SK	CS1436SK	CS1442SK	CS1448SK	CS1454SK	CS1460SK	CS1472SK
	CASE LBS. (CUBE)	6.9 (1.0)	8.52 (1.0)	10.37 (1.38)	12.54 (1.69)	13.65 (1.39)	15.69 (1.73)	17.34 (2.07)	21.08 (2.50)
	CASE KG/CUBE M <sup>3</sup>	3,13 (0,03)	3,86 (0,03)	4,7 (0,04)	5,69 (0,05)	6,19 (0,04)	7,12 (0,05)	7,87 (0,06)	9,56 (0,07)
18" 460 mm	CODE	CS1824SK	CS1830SK	CS1836SK	CS1842SK	CS1848SK	CS1854SK	CS1860SK	CS1872SK
	CASE LBS. (CUBE)	7.62 (1.0)	9.39 (1.0)	11.37 (1.38)	13.85 (1.69)	14.93 (1.39)	17.29 (1.73)	19.25 (2.07)	23.28 (2.50)
	CASE KG/CUBE M <sup>3</sup>	3,46 (0,03)	4,26 (0,03)	5,16 (0,04)	6,28 (0,05)	6,77 (0,04)	7,84 (0,05)	8,73 (0,06)	10,56 (0,07)
21" 540 mm	CODE	CS2124SK	CS2130SK	CS2136SK	CS2142SK	CS2148SK	CS2154SK	CS2160SK	CS2172SK
	CASE LBS. (CUBE)	8.54 (1.0)	10.49 (1.0)	12.79 (1.38)	15.38 (1.69)	16.84 (1.39)	19.31 (1.73)	21.38 (2.07)	25.90 (2.5)
	CASE KG/CUBE M <sup>3</sup>	3,87 (0,03)	4,76 (0,03)	5,8 (0,04)	6,98 (0,05)	7,64 (0,04)	8,76 (0,05)	9,70 (0,06)	11,75 (0,07)
24" 610 mm	CODE	CS2424SK	CS2430SK	CS2436SK	CS2442SK	CS2448SK	CS2454SK	CS2460SK	CS2472SK
	CASE LBS. (CUBE)	8.85 (1.0)	11.05 (1.0)	13.54 (1.38)	16.26 (1.69)	18.04 (1.39)	20.64 (1.73)	22.84 (2.07)	27.81 (2.50)
	CASE KG/CUBE M <sup>3</sup>	4,01 (0,03)	5,01 (0,03)	6,14 (0,04)	7,38 (0,05)	8,18 (0,04)	9,36 (0,05)	10,36 (0,06)	12,61 (0,07)





Case Pack: 1      Color: Speckled Gray (480).

# Vented Shelf Kits

									
WIDTH	LENGTH	24"	30"	36"	42"	48"	54"	60"	72"
		610 mm	760 mm	910 mm	1070 mm	1220 mm	1380 mm	1530 mm	1830 mm
14" 360 mm	CODE	CS1424VK	CS1430VK	CS1436VK	CS1442VK	CS1448VK	CS1454VK	CS1460VK	CS1472VK
	CASE LBS. (CUBE)	6.73 (1.0)	8.26 (1.0)	10.02 (1.38)	12.12 (1.69)	13.11 (1.39)	15.1 (1.73)	16.68 (2.07)	20.24 (2.5)
	CASE KG/CUBE M <sup>3</sup>	3,05 (0,03)	3,75 (0,03)	4,54 (0,04)	5,50 (0,05)	5,95 (0,04)	6,85 (0,05)	7,57 (0,06)	9,18 (0,07)
18" 460 mm	CODE	CS1824VK	CS1830VK	CS1836VK	CS1842VK	CS1848VK	CS1854VK	CS1860VK	CS1872VK
	CASE LBS. (CUBE)	7.32 (1.0)	8.98 (1.0)	10.89 (1.38)	13.23 (1.69)	14.27 (1.39)	16.49 (1.73)	18.30 (2.07)	22.14 (2.5)
	CASE KG/CUBE M <sup>3</sup>	3,32 (0,03)	4,07 (0,03)	4,94 (0,04)	6 (0,05)	6,47 (0,04)	7,48 (0,05)	8,3 (0,06)	10,04 (0,07)
21" 540 mm	CODE	CS2124VK	CS2130VK	CS2136VK	CS2142VK	CS2148VK	CS2154VK	CS2160VK	CS2172VK
	CASE LBS. (CUBE)	7.96 (1.0)	9.78 (1.0)	11.88 (1.38)	14.4 (1.69)	15.61 (1.39)	18.01 (1.73)	20.01 (2.07)	24.21 (2.5)
	CASE KG/CUBE M <sup>3</sup>	3,61 (0,03)	4,44 (0,03)	5,39 (0,04)	6,53 (0,05)	7,08 (0,04)	8,17 (0,05)	9,08 (0,06)	10,98 (0,07)
24" 610 mm	CODE	CS2424VK	CS2430VK	CS2436VK	CS2442VK	CS2448VK	CS2454VK	CS2460VK	CS2472VK
	CASE LBS. (CUBE)	8.31 (1.0)	10.38 (1.0)	12.70 (1.38)	15.35 (1.69)	16.89 (1.39)	19.43 (1.73)	21.56 (2.07)	26.22 (2.5)
	CASE KG/CUBE M <sup>3</sup>	3,77 (0,03)	4,71 (0,03)	5,76 (0,04)	6,96 (0,05)	7,66 (0,04)	8,81 (0,05)	9,78 (0,06)	11,89 (0,07)

Case Pack: 1      Color: Speckled Gray (480).

# Vented Starter Units 18" Width





WIDTH <b>18"</b> 460 mm						
HEIGHT	LENGTH	<b>36"</b> 910 mm	<b>42"</b> 1070 mm	<b>48"</b> 1220 mm	<b>54"</b> 1380 mm	<b>60"</b> 1530 mm
<b>64"</b> 1630 mm	CODE - 4 SHELVES	CSU48366	CSU48426	CSU48486	CSU48546	CSU48606
	CASE LBS. (CUBE)	72.82 (5.92)	80.24 (5.92)	85.36 (5.92)	92.22 (5.92)	98.92 (5.92)
	CASE KG/CUBE M <sup>3</sup>	33,03 (0,17)	36,4 (0,17)	38,72 (0,17)	41,83 (0,17)	44,87 (0,17)
<b>64"</b> 1630 mm	CODE - 5 SHELVES	CSU58366	CSU58426	CSU58486	CSU58546	CSU58606
	CASE LBS. (CUBE)	82.36 (5.92)	91.63 (5.92)	98.04 (5.92)	106.61 (5.92)	114.99 (5.92)
	CASE KG/CUBE M <sup>3</sup>	37,36 (0,17)	41,56 (0,17)	44,47 (0,17)	48,36 (0,17)	52,16 (0,17)
<b>72"</b> 1830 mm	CODE - 4 SHELVES	CSU48367	CSU48427	CSU48487	CSU48547	CSU48607
	CASE LBS. (CUBE)	76.34 (5.92)	83.76 (5.92)	88.89 (5.92)	95.75 (5.92)	102.44 (5.92)
	CASE KG/CUBE M <sup>3</sup>	34,63 (0,17)	37,99 (0,17)	40,32 (0,17)	43,43 (0,17)	46,47 (0,17)
<b>72"</b> 1830 mm	CODE - 5 SHELVES	CSU58367	CSU58427	CSU58487	CSU58547	CSU58607
	CASE LBS. (CUBE)	88.27 (5.92)	98.28 (5.92)	104.85 (5.92)	110.14 (5.92)	118.51 (5.92)
	CASE KG/CUBE M <sup>3</sup>	40,04 (0,17)	44,58 (0,17)	47,56 (0,17)	49,96 (0,17)	53,75 (0,17)

Case Pack: 1

Color/InStock Color: Speckled Gray (480).

Dimensions provided with line drawings above are actual dimensions.

# Vented Add-On Units





WIDTH <b>18"</b> 460 mm						
HEIGHT	LENGTH	<b>36"</b> 910 mm	<b>42"</b> 1070 mm	<b>48"</b> 1220 mm	<b>54"</b> 1380 mm	<b>60"</b> 1530 mm
<b>64"</b> 1630 mm	CODE - 4 SHELVES	CSA48366	CSA48426	CSA48486	CSA48546	CSA48606
	CASE LBS. (CUBE)	58.84 (5.92)	66.26 (5.92)	71.38 (5.92)	78.24 (5.92)	84.94 (5.92)
	CASE KG/CUBE M <sup>3</sup>	26,69 (0,17)	30,05 (0,17)	32,38 (0,17)	35,49 (0,17)	38,53 (0,17)
<b>64"</b> 1630 mm	CODE - 5 SHELVES	CSA58366	CSA58426	CSA58486	CSA58546	CSA58606
	CASE LBS. (CUBE)	68.38 (5.92)	77.65 (5.92)	84.06 (5.92)	92.63 (5.92)	101.01 (5.92)
	CASE KG/CUBE M <sup>3</sup>	31,02 (0,17)	35,22 (0,17)	38,13 (0,17)	42,02 (0,17)	45,82 (0,17)
<b>72"</b> 1830 mm	CODE - 4 SHELVES	CSA48367	CSA48427	CSA48487	CSA48547	CSA48607
	CASE LBS. (CUBE)	60.6 (5.92)	68.02 (5.92)	73.15 (5.92)	80 (5.92)	86.7 (5.92)
	CASE KG/CUBE M <sup>3</sup>	27,49 (0,17)	30,85 (0,17)	33,18 (0,17)	36,29 (0,17)	39,33 (0,17)
<b>72"</b> 1830 mm	CODE - 5 SHELVES	CSA58367	CSA58427	CSA58487	CSA58547	CSA58607
	CASE LBS. (CUBE)	70.14 (5.92)	79.41 (5.92)	85.82 (5.92)	94.4 (5.92)	102.77 (5.92)
	CASE KG/CUBE M <sup>3</sup>	31,81 (0,17)	36,02 (0,17)	38,93 (0,17)	42,82 (0,17)	46,62 (0,17)

Case Pack: 1

Color/InStock Color: Speckled Gray (480).

Dimensions provided with line drawings above are actual dimensions.

# Vented Starter Units 21" Width





WIDTH 21" 540 mm						
HEIGHT	LENGTH	36" 910 mm	42" 1070 mm	48" 1220 mm	54" 1380 mm	60" 1530 mm
64" 1630 mm	CODE - 4 SHELVES	CSU41366	CSU41426	CSU41486	CSU41546	CSU41606
	CASE LBS. (CUBE)	78 (7.39)	86.17 (7.39)	91.95 (7.39)	99.56 (7.39)	107.01 (7.39)
	CASE KG/CUBE M <sup>3</sup>	35,38 (0,21)	39,09 (0,21)	41,71 (0,21)	45,16 (0,21)	48,54 (0,21)
64" 1630 mm	CODE - 5 SHELVES	CSU51366	CSU51426	CSU51486	CSU51546	CSU51606
	CASE LBS. (CUBE)	88.53 (7.39)	98.74 (7.39)	105.97 (7.39)	115.48 (7.39)	124.79 (7.39)
	CASE KG/CUBE M <sup>3</sup>	40,16 (0,21)	44,79 (0,21)	48,07 (0,21)	52,38 (0,21)	56,60 (0,21)
72" 1830 mm	CODE - 4 SHELVES	CSU41367	CSU41427	CSU41487	CSU41547	CSU41607
	CASE LBS. (CUBE)	81.53 (7.39)	89.7 (7.39)	95.48 (7.39)	103.09 (7.39)	110.54 (7.39)
	CASE KG/CUBE M <sup>3</sup>	36,98 (0,21)	40,69 (0,21)	43,31 (0,21)	46,76 (0,21)	50,14 (0,21)
72" 1830 mm	CODE - 5 SHELVES	CSU51367	CSU51427	CSU51487	CSU51547	CSU51607
	CASE LBS. (CUBE)	92.06 (7.39)	102.27 (7.39)	109.49 (7.39)	119 (7.39)	128.32 (7.39)
	CASE KG/CUBE M <sup>3</sup>	41,76 (0,21)	46,39 (0,21)	49,66 (0,21)	53,98 (0,21)	58,20 (0,21)

Case Pack: 1

Color/InStock Color: Speckled Gray (480).

Dimensions provided with line drawings above are actual dimensions.

# Vented Add-On Units





WIDTH 21" 540 mm						
HEIGHT	LENGTH	36" 910 mm	42" 1070 mm	48" 1220 mm	54" 1380 mm	60" 1530 mm
64" 1630 mm	CODE - 4 SHELVES	CSA41366	CSA41426	CSA41486	CSA41546	CSA41606
	CASE LBS. (CUBE)	63.73 (7.39)	71.9 (7.39)	77.68 (7.39)	85.29 (7.39)	92.74 (7.39)
	CASE KG/CUBE M <sup>3</sup>	28,91 (0,21)	32,61 (0,21)	35,23 (0,21)	38,69 (0,21)	42,07 (0,21)
64" 1630 mm	CODE - 5 SHELVES	CSA51366	CSA51426	CSA51486	CSA51546	CSA51606
	CASE LBS. (CUBE)	74.26 (7.39)	84.47 (7.39)	91.7 (7.39)	101.21 (7.39)	110.52 (7.39)
	CASE KG/CUBE M <sup>3</sup>	33,68 (0,21)	38,31 (0,21)	41,59 (0,21)	45,91 (0,21)	50,13 (0,21)
72" 1830 mm	CODE - 4 SHELVES	CSA41367	CSA41427	CSA41487	CSA41547	CSA41607
	CASE LBS. (CUBE)	65.49 (7.39)	73.66 (7.39)	79.44 (7.39)	87.05 (7.39)	94.5 (7.39)
	CASE KG/CUBE M <sup>3</sup>	29,71 (0,21)	33,41 (0,21)	36,03 (0,21)	39,49 (0,21)	42,86 (0,21)
72" 1830 mm	CODE - 5 SHELVES	CSA51367	CSA51427	CSA51487	CSA51547	CSA51607
	CASE LBS. (CUBE)	76.02 (7.39)	86.23 (7.39)	93.46 (7.39)	102.97 (7.39)	112.28 (7.39)
	CASE KG/CUBE M <sup>3</sup>	34,48 (0,21)	39,11 (0,21)	42,39 (0,21)	46,71 (0,21)	50,93 (0,21)

Case Pack: 1

Color/InStock Color: Speckled Gray (480).





Dimensions provided with line drawings above are actual dimensions.

# Vented Starter Units 24" Width

WIDTH <b>24"</b> 610 mm						
HEIGHT	LENGTH	<b>36"</b> 910 mm	<b>42"</b> 1070 mm	<b>48"</b> 1220 mm	<b>54"</b> 1380 mm	<b>60"</b> 1530 mm
<b>64"</b> 1630 mm	CODE - 4 SHELVES	CSU44366	CSU44426	CSU44486	CSU44546	CSU44606
	CASE LBS. (CUBE)	83.18 (8.49)	91.88 (8.49)	99.01 (8.49)	107.14 (8.49)	115.12 (9.46)
	CASE KG/CUBE M <sup>3</sup>	37,73 (0,24)	41,68 (0,24)	44,91 (0,24)	48,6 (0,24)	52,22 (0,27)
<b>64"</b> 1630 mm	CODE - 5 SHELVES	CSU54366	CSU54426	CSU54486	CSU54546	CSU54606
	CASE LBS. (CUBE)	94.53 (8.49)	105.4 (8.49)	114.31 (8.49)	124.48 (8.49)	134.44 (9.46)
	CASE KG/CUBE M <sup>3</sup>	42,88 (0,24)	47,81 (0,24)	51,85 (0,24)	56,46 (0,24)	60,98(0,27)
<b>72"</b> 1830 mm	CODE - 4 SHELVES	CSU44367	CSU44427	CSU44487	CSU44547	CSU44607
	CASE LBS. (CUBE)	86.71 (8.49)	95.4 (8.49)	102.53 (8.49)	110.66 (8.49)	123.76 (9.46)
	CASE KG/CUBE M <sup>3</sup>	39,33 (0,24)	43,27 (0,24)	46,51 (0,24)	50,19 (0,24)	56,14 (0,27)
<b>72"</b> 1830 mm	CODE - 5 SHELVES	CSU54367	CSU54427	CSU54487	CSU54547	CSU54607
	CASE LBS. (CUBE)	102.29 (8.49)	113.48 (8.49)	123.59 (8.49)	128 (8.49)	144.37 (9.46)
	CASE KG/CUBE M <sup>3</sup>	46,4 (0,24)	51,47 (0,24)	56,06 (0,24)	58,06 (0,24)	65,48 (0,27)

Case Pack: 1 Color: Speckled Gray (480). Dimensions provided with line drawings above are actual dimensions.

# Vented Add-On Units

WIDTH <b>24"</b> 610 mm						
HEIGHT	LENGTH	<b>36"</b> 910 mm	<b>42"</b> 1070 mm	<b>48"</b> 1220 mm	<b>54"</b> 1380 mm	<b>60"</b> 1530 mm
<b>64"</b> 1630 mm	CODE - 4 SHELVES	CSA44366	CSA44426	CSA44486	CSA44546	CSA44606
	CASE LBS. (CUBE)	68.42 (8.49)	77.12 (8.49)	84.24 (8.49)	92.38 (8.49)	100.35 (9.46)
	CASE KG/CUBE M <sup>3</sup>	31,03 (0,24)	34,98 (0,24)	38,21 (0,24)	41,90 (0,24)	45,52 (0,27)
<b>64"</b> 1630 mm	CODE - 5 SHELVES	CSA54366	CSA54426	CSA54486	CSA54546	CSA54606
	CASE LBS. (CUBE)	79.77 (8.49)	90.64 (8.49)	99.54 (8.49)	109.71 (8.49)	119.68 (9.46)
	CASE KG/CUBE M <sup>3</sup>	36,18 (0,24)	41,11 (0,24)	45,15 (0,24)	49,76 (0,24)	54,29 (0,27)
<b>72"</b> 1830 mm	CODE - 4 SHELVES	CSA44367	CSA44427	CSA44487	CSA44547	CSA44607
	CASE LBS. (CUBE)	70.18 (8.49)	78.88 (8.49)	86 (8.49)	94.14 (8.49)	102.11 (9.46)
	CASE KG/CUBE M <sup>3</sup>	31,83 (0,24)	35,78 (0,24)	39,01 (0,24)	42,70 (0,24)	46,32 (0,27)
<b>72"</b> 1830 mm	CODE - 5 SHELVES	CSA54367	CSA54427	CSA54487	CSA54547	CSA54607
	CASE LBS. (CUBE)	81.53 (8.49)	92.4 (8.49)	101.31 (8.49)	111.47 (8.49)	121.44 (9.46)
	CASE KG/CUBE M <sup>3</sup>	36,98 (0,24)	41,91 (0,24)	45,95 (0,24)	50,56 (0,24)	55,08 (0,27)

Case Pack: 1 Color: Speckled Gray (480). Dimensions provided with line drawings above are actual dimensions.

# 84" Shelving

- 84" (2140 mm) Camshelving® provides maximum storage capacity in limited space.
- Ideal for operations with high product turnover and extensive menu offerings.
- Add a dunnage stand for greater stability and weight bearing capability.





**DUE TO THE HEAVY WEIGHT OF 84" (2140 MM) SHELVING, STARTER AND ADD-ON UNITS WILL BE SHIPPED IN MULTIPLE CARTONS.**

**Starter Units** will ship in three separate cartons: two cartons containing one post kit each, and one carton containing five sets of shelf kits.

**Add-On Units** will ship in two separate cartons: one carton containing one post kit and one carton containing five sets of shelf kits.







## Vented Starter Units 24" Width

WIDTH <b>24"</b> 610 mm						
HEIGHT	LENGTH	<b>36"</b> 910 mm	<b>42"</b> 1070 mm	<b>48"</b> 1220 mm	<b>54"</b> 1380 mm	<b>60"</b> 1530 mm
<b>84"</b> 2140 mm	CODE - 5 SHELVES	CSU54368PKG480	CSU54428PKG480	CSU54488PKG480	CSU54548PKG480	CSU54608PKG480
	POST KIT BOX (2)	2 Post Kits	2 Post Kits	2 Post Kits	2 Post Kits	2 Post Kits
	CASE LBS. (CUBE)	40.16 (1.23)	40.16 (1.23)	40.16 (1.23)	40.16 (1.23)	40.16 (1.23)
	CASE KG (CUBE M³)	18,22 (0,0346)	18,22 (0,0346)	18,22 (0,0346)	18,22 (0,0346)	18,22 (0,0346)
	SHELF KIT BOX (1)	Set of 5 Shelf Kits	Set of 5 Shelf Kits	Set of 5 Shelf Kits	Set of 5 Shelf Kits	Set of 5 Shelf Kits
	CASE LBS. (CUBE)	62.77 (5.28)	73.57 (6.16)	83.1 (7.04)	95.85 (7.92)	104.64 (8.8)
CASE KG (CUBE M³)	28,47 (0,15)	33,37 (0,174)	37,69 (0,199)	43,48 (0,224)	47,46 (0,249)	

**Case Pack:** Three cartons per unit  
Shipping weight listed above is per carton.

**Color:** Speckled Gray (480). Dimensions provided with line drawings above are actual dimensions.

## Vented Add-On Units

WIDTH <b>24"</b> 610 mm						
HEIGHT	LENGTH	<b>36"</b> 910 mm	<b>42"</b> 1070 mm	<b>48"</b> 1220 mm	<b>54"</b> 1380 mm	<b>60"</b> 1530 mm
<b>84"</b> 2140 mm	CODE - 5 SHELVES	CSA54368PKG480	CSA54428PKG480	CSA54488PKG480	CSA54548PKG480	CSA54608PKG480
	POST KIT BOX (1)	1 Post Kit	1 Post Kit	1 Post Kit	1 Post Kit	1 Post Kit
	CASE LBS. (CUBE)	20.08 (0.61)	20.08 (0.61)	20.08 (0.61)	20.08 (0.61)	20.08 (0.61)
	CASE KG (CUBE M³)	9,11 (0,02)	9,11 (0,02)	9,11 (0,02)	9,11 (0,02)	9,11 (0,02)
	SHELF KIT BOX (1)	Set of 5 Shelf Kits	Set of 5 Shelf Kits	Set of 5 Shelf Kits	Set of 5 Shelf Kits	Set of 5 Shelf Kits
	CASE LBS. (CUBE)	62.77 (5.28)	73.57 (6.16)	83.1 (7.04)	95.85 (7.92)	104.64 (8.8)
CASE KG (CUBE M³)	28,47 (0,15)	33,37 (0,17)	37,69 (0,20)	43,48 (0,22)	47,46 (0,25)	

**Case Pack:** Two cartons per unit

**Color:** Speckled Gray (480). Dimensions provided with line drawings above are actual dimensions.



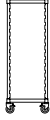
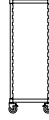
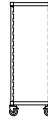



# Mobile Post Kits & Casters

<b>Mobile Post Kits</b> Casters are not included and must be ordered separately.				
<b>HEIGHT</b>	<b>WIDTH</b>	<b>18"</b>	<b>21"</b>	<b>24"</b>
		460 mm	540 mm	610 mm
<b>35"</b> 890 mm	<b>CODE</b>	CSPRK1835	CSPRK2135	CSPRK2435
	<b>CASE LBS. (CUBE)</b>	7.93 (0.32)	8.23 (0.32)	8.72 (0.32)
	<b>CASE KG/CUBE M³</b>	3,6 (0,0091)	3,73 (0,0091)	3,96 (0,0091)
<b>59"</b> 1500 mm	<b>CODE</b>	CSPRK1859	CSPRK2159	CSPRK2459
	<b>CASE LBS. (CUBE)</b>	12.93 (0.41)	13.23 (0.41)	13.72 (0.41)
	<b>CASE KG/CUBE M³</b>	5,86 (0,0116)	6 (0,0116)	6,22 (0,0116)
<b>67"</b> 1700 mm	<b>CODE</b>	CSPRK1867	CSPRK2167	CSPRK2467
	<b>CASE LBS. (CUBE)</b>	14.57 (0.46)	14.86 (0.46)	15.35 (0.46)
	<b>CASE KG/CUBE M³</b>	6,61 (0,01)	6,74 (0,01)	6,96 (0,01)
<b>75"</b> 1910 mm	<b>CODE</b>	CSPRK1875	CSPRK2175	CSPRK2475
	<b>CASE LBS. (CUBE)</b>	16.43 (0.52)	16.73 (0.52)	17.22 (0.52)
	<b>CASE KG/CUBE M³</b>	7,45 (0,01)	7,59 (0,01)	7,81 (0,01)

Case Pack: 1

Color: Speckled Gray (480).

Casters are not included and must be ordered separately.

<b>Casters</b>		Premium	Premium	Standard	Standard	Standard	Donut Bumper
							
	<b>DIAMETER</b>	<b>5"</b>	<b>5"</b>	<b>5"</b>	<b>5"</b>	<b>5"</b>	<b>3 1/2"</b>
		127 mm	127 mm	127 mm	127 mm	127 mm	90 mm
	<b>CODE</b>	CSCSL	CSCTL	CSSB	CSCS	CSCR	CSRDB
	<b>DESCRIPTION</b>	Swivel with lock in one direction	Total Locking Caster	Swivel Chrome with Brake	Swivel Chrome Caster	Rigid Chrome Caster	Donut Bumper
	<b>CASE LBS. (CUBE)</b>	2.16 (0.16)	2.17 (0.16)	2.41 (0.16)	2.22 (0.16)	2.35 (0.16)	0.74 (0.05)
	<b>CASE KG (CUBE M³)</b>	0,98 (0,004)	0,98 (0,004)	1,09 (0,004)	1,01 (0,004)	1,07 (0,004)	0,34 (0,001)





Caster Case Pack: 2

Donut Bumper Case Pack: 4.

**PREMIUM CASTERS** The premium line is made with a zinc plated post and a non-marking polyurethane wheel. Recommended for use in wet areas or in walk-in refrigerators and freezers.





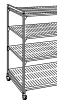

**STANDARD CASTERS** The standard casters are chrome plated and can be used for dry storage.

# Vented Mobile Starter Units







		Premium	Standard	Premium	Standard	Premium	Standard
<b>WIDTH</b> <b>18"</b> 460 mm							
<b>HEIGHT</b> (with casters)	<b>LENGTH</b>	<b>36"</b>	<b>36"</b>	<b>42"</b>	<b>42"</b>	<b>48"</b>	<b>48"</b>
		910 mm	910 mm	1070 mm	1070 mm	1220 mm	1220 mm
<b>67"</b> 1700 mm	<b>CODE - 4 SHELVES</b>	CSUR48366	CSURS48366	CSUR48426	CSURS48426	CSUR48486	CSURS48486
	<b>CASE LBS. (CUBE)</b>	80.01 (5.92)	80.62 (5.92)	87.43 (5.92)	88.04 (5.92)	92.56 (5.92)	93.17 (5.92)
	<b>CASE KG/CUBE M<sup>3</sup></b>	36,29 (0,17)	36,57 (0,17)	39,66 (0,17)	39,93 (0,17)	41,98 (0,17)	42,26 (0,17)
<b>67"</b> 1700 mm	<b>CODE - 5 SHELVES</b>	CSUR58366	CSURS58366	CSUR58426	CSURS58426	CSUR58486	CSURS58486
	<b>CASE LBS. (CUBE)</b>	89.55 (5.92)	90.16 (5.92)	98.83 (5.92)	99.43 (5.92)	105.24 (5.92)	105.85 (5.92)
	<b>CASE KG/CUBE M<sup>3</sup></b>	40,62 (0,17)	40,90 (0,17)	44,83 (0,17)	45,10 (0,17)	47,74 (0,17)	48,01 (0,17)
<b>75"</b> 1910 mm	<b>CODE - 4 SHELVES</b>	CSUR48367	CSURS48367	CSUR48427	CSURS48427	CSUR48487	CSURS48487
	<b>CASE LBS. (CUBE)</b>	83.34 (5.92)	83.95 (5.92)	90.76 (5.92)	91.37 (5.92)	95.89 (5.92)	96.5 (5.92)
	<b>CASE KG/CUBE M<sup>3</sup></b>	37,80 (0,17)	38,08 (0,17)	41,17 (0,17)	41,44 (0,17)	43,49 (0,17)	43,77 (0,17)
<b>75"</b> 1910 mm	<b>CODE - 5 SHELVES</b>	CSUR58367	CSURS58367	CSUR58427	CSURS58427	CSUR58487	CSURS58487
	<b>CASE LBS. (CUBE)</b>	92.89 (5.92)	93.49 (5.92)	102.16 (5.92)	102.77 (5.92)	108.57 (5.92)	109.18 (5.92)
	<b>CASE KG/CUBE M<sup>3</sup></b>	42,13 (0,17)	42,41 (0,17)	46,34 (0,17)	46,62 (0,17)	49,25 (0,17)	49,52 (0,17)

Case Pack: 1 Color: Speckled Gray (480).

**Premium Casters:** include two non-corrosive swivel locking casters (CSCSL) and two total locking casters (CSCTL).  
**Standard Casters:** include two swivel chrome casters (CSCS) and two swivel chrome with brakes (CSSB).

		Premium	Standard	Premium	Standard	Premium	Standard
<b>WIDTH</b> <b>21"</b> 540 mm							
<b>HEIGHT</b> (with casters)	<b>LENGTH</b>	<b>36"</b>	<b>36"</b>	<b>42"</b>	<b>42"</b>	<b>48"</b>	<b>48"</b>
		910 mm	910 mm	1070 mm	1070 mm	1220 mm	1220 mm
<b>67"</b> 1700 mm	<b>CODE - 4 SHELVES</b>	CSUR41366	CSURS41366	CSUR41426	CSURS41426	CSUR41486	CSURS41486
	<b>CASE LBS. (CUBE)</b>	85.2 (7.39)	85.81 (7.39)	93.37 (7.39)	93.98 (7.39)	99.15 (7.39)	99.75 (7.39)
	<b>CASE KG/CUBE M<sup>3</sup></b>	38,65 (0,21)	38,92 (0,21)	42,35 (0,21)	42,63 (0,21)	44,97 (0,21)	45,25 (0,21)
<b>67"</b> 1700 mm	<b>CODE - 5 SHELVES</b>	CSUR51366	CSURS51366	CSUR51426	CSURS51426	CSUR51486	CSURS51486
	<b>CASE LBS. (CUBE)</b>	95.73 (7.39)	96.33 (7.39)	105.94 (7.39)	106.55 (7.39)	113.16 (7.39)	113.77 (7.39)
	<b>CASE KG/CUBE M<sup>3</sup></b>	43,42 (0,21)	43,99 (0,21)	48,05 (0,21)	48,33 (0,21)	51,33 (0,21)	51,60 (0,21)
<b>75"</b> 1910 mm	<b>CODE - 4 SHELVES</b>	CSUR41367	CSURS41367	CSUR41427	CSURS41427	CSUR41487	CSURS41487
	<b>CASE LBS. (CUBE)</b>	88.53 (7.39)	89.14 (7.39)	96.7 (7.39)	97.31 (7.39)	102.48 (7.39)	103.09 (7.39)
	<b>CASE KG/CUBE M<sup>3</sup></b>	40,16 (0,21)	40,43 (0,21)	43,86 (0,21)	44,14 (0,21)	46,48 (0,21)	46,76 (0,21)
<b>75"</b> 1910 mm	<b>CODE - 5 SHELVES</b>	CSUR51367	CSURS51367	CSUR51427	CSURS51427	CSUR51487	CSURS51487
	<b>CASE LBS. (CUBE)</b>	99.06 (7.39)	99.67 (7.39)	109.27 (7.39)	109.88 (7.39)	116.5 (7.39)	117.1 (7.39)
	<b>CASE KG/CUBE M<sup>3</sup></b>	44,93 (0,21)	45,21 (0,21)	49,56 (0,21)	49,84 (0,21)	52,84 (0,21)	53,12 (0,21)

# Vented Mobile Starter Units



		Premium	Standard	Premium	Standard	Premium	Standard
<b>WIDTH</b> <b>24"</b> 610 mm							
<b>HEIGHT</b> (with casters)	<b>LENGTH</b>	<b>36"</b> 910 mm	<b>36"</b> 910 mm	<b>42"</b> 1070 mm	<b>42"</b> 1070 mm	<b>48"</b> 1220 mm	<b>48"</b> 1220 mm
<b>67"</b> 1700 mm	<b>CODE - 4 SHELVES</b>	CSUR44366	CSURS44366	CSUR44426	CSURS44426	CSUR44486	CSURS44486
	<b>CASE LBS. (CUBE)</b>	90.38 (8.49)	90.99 (8.49)	99.07 (8.49)	99.68 (8.49)	106.2 (8.49)	106.81 (8.49)
	<b>CASE KG/CUBE M³</b>	41 (0,24)	41,27 (0,24)	44,94 (0,24)	45,21 (0,24)	48,17 (0,24)	48,45 (0,24)
<b>67"</b> 1700 mm	<b>CODE - 5 SHELVES</b>	CSUR54366	CSURS54366	CSUR54426	CSURS54426	CSUR54486	CSURS54486
	<b>CASE LBS. (CUBE)</b>	101.72 (8.49)	102.33 (8.49)	112.59 (8.49)	113.2 (8.49)	121.5 (8.49)	122.11 (8.49)
	<b>CASE KG/CUBE M³</b>	46,14 (0,24)	46,42 (0,24)	51,07 (0,24)	51,35 (0,24)	55,11 (0,24)	55,39 (0,24)
<b>75"</b> 1910 mm	<b>CODE - 4 SHELVES</b>	CSUR44367	CSURS44367	CSUR44427	CSURS44427	CSUR44487	CSURS44487
	<b>CASE LBS. (CUBE)</b>	93.71 (8.49)	94.32 (8.49)	106.06 (8.49)	103.01 (8.49)	109.53 (8.49)	110.14 (8.49)
	<b>CASE KG/CUBE M³</b>	42,51 (0,24)	42,78 (0,24)	48,11 (0,24)	46,72 (0,24)	49,68 (0,24)	49,96 (0,24)
<b>75"</b> 1910 mm	<b>CODE - 5 SHELVES</b>	CSUR54367	CSURS54367	CSUR54427	CSURS54427	CSUR54487	CSURS54487
	<b>CASE LBS. (CUBE)</b>	105.06 (8.49)	105.66 (8.49)	115.93 (8.49)	116.53 (8.49)	124.83 (8.49)	125.44 (8.49)
	<b>CASE KG/CUBE M³</b>	47,65 (0,24)	47,93 (0,24)	52,58 (0,24)	52,86 (0,24)	56,62 (0,24)	56,9 (0,24)

Case Pack: 1 Color: Speckled Gray (480).

**Premium Casters:** include two non-corrosive swivel locking casters (CSCSL) and two total locking casters (CSCTL).

**Standard Casters:** include two swivel chrome casters (CSCS) and two swivel chrome with brakes (CSSB).

# Fence System

PRODUCT	FITS	24"	30"	36"	42"	48"	54"	60"	72"
	<b>Traverse</b>	610 mm	760 mm	910 mm	1070 mm	1220 mm	1380 mm	1530 mm	1830 mm
	<b>CODE</b>	CSFT242	CSFT302	CSFT362	CSFT422	CSFT482	CSFT542	CSFT602	CSFT722
	<b># OF BRACKETS</b>	2	2	2	3	4	4	4	5
	<b># OF RODS</b>	2	2	2	2	2	2	2	2
	<b>CASE LBS. (CUBE)</b>	1.94 (0.23)	2.06 (0.30)	2.17 (0.37)	2.31 (0.43)	2.43 (0.50)	2.56 (0.57)	2.68 (0.64)	2.93 (0.77)
	<b>CASE KG (CUBE M³)</b>	3,53 (0,0235)	4,36 (0,0235)	5,19 (0,0235)	6,03 (0,0274)	6,85 (0,0300)	7,68 (0,035)	18,30 (0,039)	10,07 (0,047)
	<b>CODE</b>	CSFT241	CSFT301	CSFT361	CSFT421	CSFT481	CSFT541	CSFT601	CSFT721
	<b># OF BRACKETS</b>	2	2	2	3	3	4	4	5
	<b># OF RODS</b>	1	1	1	1	1	1	1	1
	<b>CASE LBS. (CUBE)</b>	1.74 (0.13)	1.80 (0.17)	1.86 (0.21)	1.91 (0.25)	1.99 (0.29)	2.07 (0.33)	2.13 (0.37)	2.27 (0.45)
	<b>CASE KG (CUBE M³)</b>	3,78 (0,0235)	4,63 (0,0235)	5,47 (0,0235)	6,53 (0,0274)	7,16 (0,03)	8,22 (0,0351)	9,05 (0,039)	10,84 (0,047)

PRODUCT	FITS	14"	18"	21"	24"
	<b>Post Connector</b>	360 mm	460 mm	540 mm	610 mm
	<b>CODE</b>	CSFE14	CSFE18	CSFE21	CSFE24
	<b># OF BRACKETS</b>	2	2	2	2
	<b># OF RODS</b>	2	2	2	2
	<b>CASE LBS. (CUBE)</b>	1.73 (0.03)	1.81 (0.05)	1.87 (0.06)	1.93 (0.07)
	<b>CASE KG (CUBE M³)</b>	3,53 (0,0235)	4,36 (0,0235)	5,19 (0,0235)	6,03 (0,0274)

Case Pack: 1

Color: Speckled Gray (480).



# Camshelving® High Density Storage System

High Density Camshelving maximizes storage capacity by eliminating aisles and utilizing all available space. Ideal for operations with limited space or that need to use their space more effectively. Floor track system provides safe and easy access to stored product. Heavy weight loads roll securely on raised floor track.



COMPONENTS

*Increases Storage Capacity up to*  
**40%**

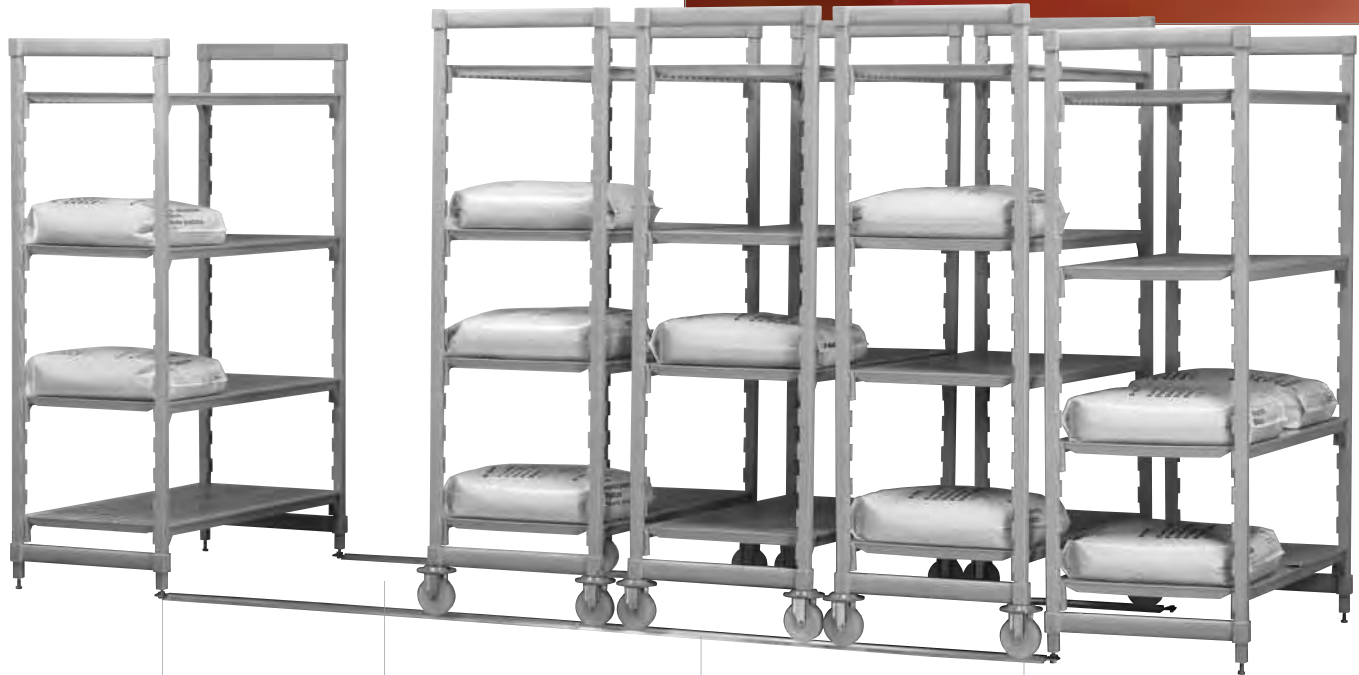

**Easy Glide Floor Tracks**  
The track simply connects to the bottom of the Stationary Camshelving Unit. No bolts or drilling into the floor are required.

**Ergonomic Access to Stored Product**  
Active aisle of 30"-36" provides easy access to all stored product. Low profile sloped rail design ensures easy access to product using the active aisle.

**Raised Track**  
Raised track provides a smooth and level surface to easily roll mobile units. It ensures dirt will not get trapped, and is easy to clean. Mobile Units with heavy weight loads roll smoothly on track.

**Roll Easily and Securely**  
Grooved casters roll easily and securely on raised track. Can be used on any surface, including tile and chippy floors.



## Easy to Clean

- Camshelving is the most hygienic high density storage system available.
- Raised track ensures dirt will not get trapped, and is easy to clean.
- Aluminum track and stainless steel hardware are rust resistant.
- Shelf plates easily wipe clean or can be removed and run through the dishwasher.

# Camshelving® High Density Storage System

## Easy to Order

- Camshelving stationary units act as the system anchor.
- Mobile units with exclusive high density casters are available with vented or solid shelves.
- Mobile units can be ordered in convenient starter units, or custom built using Camshelving mobile post kits, shelf kits and high density casters.\*
- Raised track kits ship with all hardware necessary for installation.

\* Refer to pages 64 and 69 for components to build custom size mobile Camshelving units.

## Easy to Configure and Assemble

1. Determine your room size and needs. Multiple track kits can be used together to build the desired length of track.\*\*
2. Choose starter unit size. Existing Camshelving stationary units can be retrofitted and utilized as the system anchors.
3. Select high density mobile units. Choose either starter units, or build custom size units from components.
4. Different width stationary and mobile units may be used in a single run of track.

\*\* It is recommended to use a stationary unit for every 15' of track to further stabilize the system.

## System Components

- A Stationary Units
- B Mobile Units
- C Track
- D Active Aisle

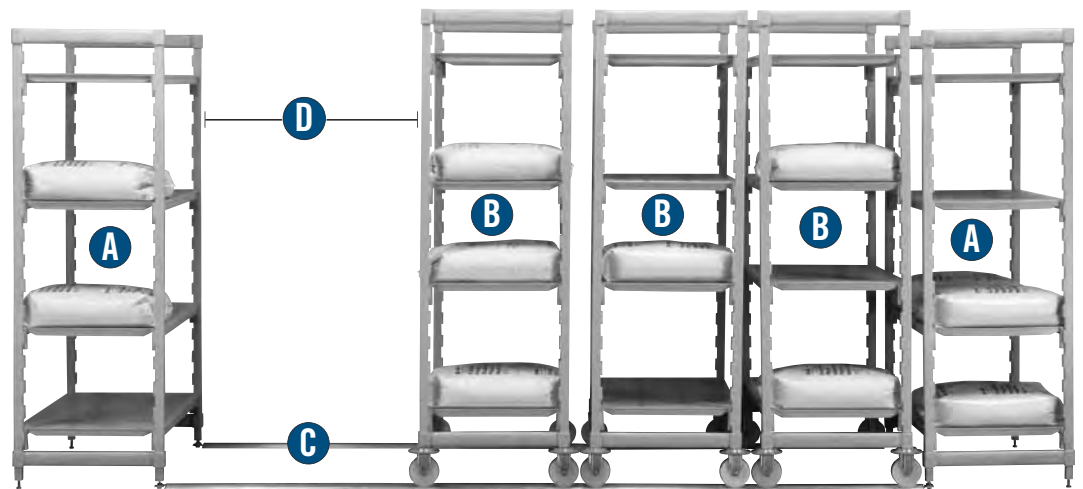

High Density Mobile Units include 4 High Density Casters.

Weight bearing capacity of High Density Mobile Camshelving Units is 750 lbs. (340 Kg).

It is recommended to use Fencing with High Density Camshelving. Refer to page 71 for product details.

All necessary hardware is included in the track kit.

CODE	DESCRIPTION	SIZE	CASE PACK	CASE LBS. (CUBE)
<b>Track Kits</b>				
CSHDTK10	10' Track Kit for 3 Mobile Units*	120"	1	23.4 (0.34)
CSHDTK12	12' Track Kit for 4 Mobile Units*	144"	1	27.2 (0.40)
CSHDTK145	14.5' Track Kit for 5 Mobile Units*	174"	1	32.3 (0.6)
<b>High Density Mobile Starter Units with Vented Shelves</b>				
CSUHD44486	Mobile Unit 4 Vented Shelves	24" x 48" x 67"	1	105.66 (8.49)
CSUHD44487	Mobile Unit 4 Vented Shelves	24" x 48" x 75"	1	108.99 (8.49)
CSUHD44427	Mobile Unit 4 Vented Shelves	24" x 42" x 75"	1	101.87 (8.49)
CSUHD44367	Mobile Unit 4 Vented Shelves	24" x 36" x 75"	1	93.17 (8.49)
<b>High Density Mobile Starter Units with Solid Shelves</b>				
CSUHD44486S	Mobile Unit 4 Solid Shelves	24" x 48" x 67"	1	110.27 (8.49)
CSUHD44487S	Mobile Unit 4 Solid Shelves	24" x 48" x 75"	1	113.6 (8.49)
CSUHD44427S	Mobile Unit 4 Solid Shelves	24" x 42" x 75"	1	115.52 (8.49)
CSUHD44367S	Mobile Unit 4 Solid Shelves	24" x 36" x 75"	1	96.56 (8.49)
<b>Accessories</b>				
CSHDDB	High Density Donut Bumper		4	2.01 (0.05)
CSHDC	High Density Caster		2	4.10 (0.16)

**Color:** Speckled Gray (480) **Track Kits Color:** (000)

\* Track holds up to 24" wide mobile units.

# Security Cage For Camshelving®

- Provides safe storage for valuables such as steaks, seafood, wine, champagne and spirits.
- Stainless steel material is safe for use in coolers and freezers.
- Ideal for securing personal items such as purses and backpacks.
- Unique modular design provides the flexibility to retrofit one shelf at a time or an entire shelving unit.

Ideal for use in coolers and freezers.



Fits on US Standard Camshelving and Elements Series Units 24" (61 cm) wide, 48" (122 cm) in length and longer.



CODE	DIMENSIONS W x L x H	CASE LBS. (CUBE)
CSSC2448	25¼" x 42½" x 18" (64 x 108 x 46 cm)	31½ (5.73)

Case Pack: 1 Padlock not included.

# Divider Bar for Camshelving®

- Creates a custom storage unit that can accommodate a variety of storage products and sizes on a single Camshelving unit.
- Angled and straight designs hold food pans and boxes straight or on an angle for more ergonomic reach.
- Divider bars fit on 24" (610 mm) wide Camshelving units and hold up to 200 lbs. (91 Kg) per shelf.
- Divider bars feature a raised bar on the front edge to keep racks and pans from sliding off the front of the unit.



Camracks® fit on divider bars to create a warewashing drying and storage station.



Divider bars can accommodate any size food pans from GN 1/1 to GN 1/9.

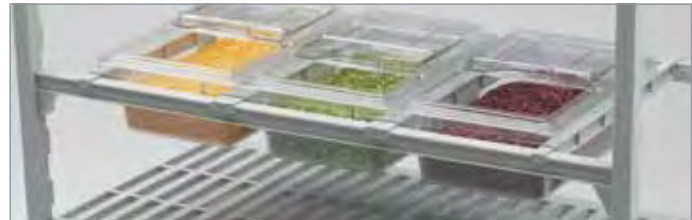

12" x 18" food boxes with sliding lids can be used with divider bars for hygienic food storage.

CODE	DESCRIPTION	CASE LBS. (CUBE)
CSDBA	Divider Bar Angled	1.9 (0.096)
CSDBS	Divider Bar Straight	1.9 (0.096)

Case Pack: 4 Color: Speckled Gray (480).

# Tray Slide Rack for Camshelving®

- Holds six 18" x 26" sheet pans.
- Made from Aluminum which is safe for use in coolers and freezers.
- Fits on Camshelving and Camshelving Elements Series Units 24" wide and 24" in length or longer.

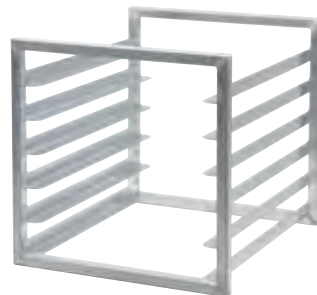

CODE	DIMENSIONS D x L x H	CASE LBS. (CUBE)
CSTSR	23" x 20⅞" x 20"	15 (5.65)

Case Pack: 1 InStock Color: (000).

# Camshelving® Wall Shelves And Storesafe® Shelf Extenders

## Wall Shelves

- Expand storage space in kitchens, above work stations and sinks.
- Features virtually indestructible I-beam supports that hold up to 150 lbs. (68 Kg) per shelf.
- Durable polypropylene withstands temperatures up to 190°F (88°C), and will not rust or corrode.
- Snap fit rail design allows shelves to snap on and off for easy cleaning.
- 2" (5 cm) backsplash and marine front edge controls spills and cross contamination.

## Shelf Extenders

- Convert empty wall space into a functional storage area.
- Use with or without Camshelving Wall Shelves.
- Peg strips withstand temperatures up to 190°F (88°C), and will not rust or corrode.

Wall Shelf Color: Speckled Gray (480).

Extender Peg Strip Color: Black (110).

Wall Shelf Kits are covered by the following U.S. Patents D 508,646S & D 512,867 S.



COMPONENTS

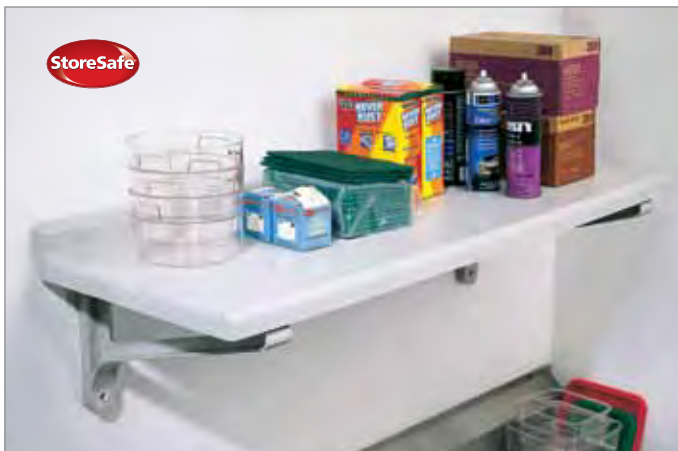

Shelf Extenders ship in one carton with all hardware and includes:

LENGTH	PEG STRIPS	BRACKETS	HOOKS
36"	3	2	6
48"	3	3	9



CODE	CSWS1436SK	CSWS1448SK	CSWS1436VK	CSWS1448VK
DESCRIPTION	36" x 14" Wall Shelf, Solid	48" x 14" Wall Shelf, Solid	36" x 14" Wall Shelf, Vented	48" x 14" Wall Shelf, Vented
EXTERIOR DIMENSIONS	L 36" x W 14" x H 13½"	L 48" x W 14" x H 13½"	L 36" x W 14" x H 13½"	L 48" x W 14" x H 13½"
CASE LBS. (CUBE)	10 (1.31)	12.50 (1.73)	9.75 (1.31)	11.50 (1.73)

Case Pack: 1

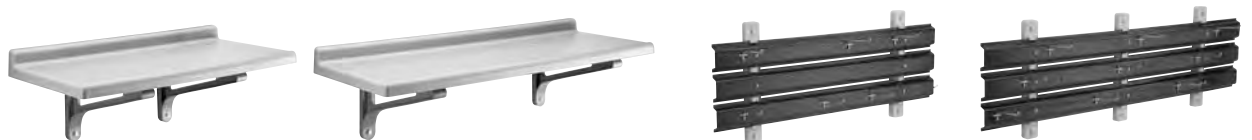

CODE	CSWS1836SK	CSWS1848SK	CSWS36EK	CSWS48EK
DESCRIPTION	36" x 18" Wall Shelf, Solid	48" x 18" Wall Shelf, Solid	36" Shelf Extender	48" Shelf Extender
EXTERIOR DIMENSIONS	L 36" x W 18" x H 13½"	L 48" x W 18" x H 13½"	L 35½" x W 2" x H 15½"	L 47½" x W 2" x H 15½"
CASE LBS. (CUBE)	11.77 (1.54)	14.45 (2.05)	6 (0.37)	8.25 (0.49)

Case Pack: 1