

Camshelving®

ELEMENTS SERIES



The Future of Shelving



Strong as Steel

State-of-the-art, composite material is as strong as steel.



Lifetime Warranty

Lifetime warranty against rust and corrosion, ideal for use in cold, hot, wet and dry environments.



Easy To Clean

Dishwasher safe, removable shelf plates are embedded with Camguard® antimicrobial protection.



Camshelving® Elements Series

STRONG TECHNOLOGY



- Composite material is as strong as steel.
- 78" (1980 mm) stationary traverse is the longest and strongest in the industry; supports loads up to 600 lbs. (272 Kg) per shelf.
- 60% lighter in weight than steel; easy to set up, adjust and change configurations.
- Resistant to moisture; won't rust or corrode.

HYGIENIC DESIGN



- Non-porous surface simply wipes clean.
- Shelf plates are easily removed for thorough dishwasher cleaning.
- Camguard® Antimicrobial protection is permanently embedded in shelf plates.
- Camguard works continuously to suppress the growth of microbes between cleanings.

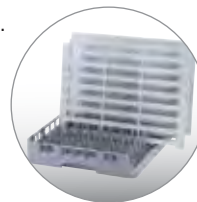

SHELVING FOR LIFE



- Lifetime warranty against corrosion and rust.
- Withstands temperatures as cold as -36°F (-38°C) or warm environments up to 190°F (88°C).
- Ideal for wet, dry, cold or humid environments.
- Impervious to moisture and chemicals.
- Won't peel, dent or warp; corrosion resistant.

Weight Capacity

	TRAVERSE LENGTH	WEIGHT BEARING CAPACITY	
		PER SHELF	PER UNIT
Single Unit (4 shelves)	30" - 48" 760 mm - 1220 mm	800 lbs. 363 Kg	3200 lbs. 1451 Kg
Single Unit (4 shelves)	54" - 78" 1380 mm - 1530 mm	600 lbs. 272 Kg	2400 lbs. 1089 Kg
Dunnage Stand	54" - 78" 1380 mm - 1980 mm	1000 lbs. 454 Kg bottom shelf only	—
Corner Unit (4 shelves)	36" - 48" 910 mm - 1220 mm	400 lbs. 180 Kg	1600 lbs. 720 Kg
Mobile Unit (4 shelves)	36" - 60" 910 mm - 1530 mm	—	900 lbs. 409 Kg

Dunnage Stands are recommended for units 54" (1380 mm) or longer.

Corner Connectors are recommended for use on traverses 48" (1220 mm) or less.

Due to the weight bearing capacity of casters, maximum weight load on an entire Mobile Elements unit is 900 lbs. (409 Kg)



Camshelving® Elements Series Stationary Traverse Dovetails are covered by Patent # D623,929. Camshelving® Elements Series Stationary Traverse Corner Connectors are covered by Patent # D624,764. Other Camshelving® Elements Series Components are Patent Pending.

Maximize Space Utilization

Elements is available in partially assembled starter and add-on units for ease of ordering and assembly.

4-Shelf Stationary Starter Units

- Ship complete in one box with two post kits, 8 stationary traverses, 32 stationary dovetails and shelf plates to build one entire unit.



Dunnage Stand

- Increases weight bearing capacity to 1000 lbs. (454 Kg) on the bottom shelf.
- Recommended for units 54" (1380 mm) or longer.

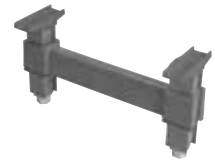

4-Shelf Add-On Units

- Ship complete in one box with one post kit, 8 traverses, 32 dovetails and shelf plates to attach to an adjoining unit.
- The traverses on both units share the middle posts, maximizing space.
- No add-on clips or S-hooks required.
- No loss of weight bearing capacity when built in a straight line.



Seismic Foot

- Bolts a post to the floor for a more stable base.
- Screws not included.



Corner Units & U-Shape Units

- Corner connectors can be used to build Corner and U-Shaped units.
- Corner connectors easily snap onto traverses.
- Corner connector set attaches a starter unit to a second unit at a 90° angle or to form a U-shape.
- A set of corner connectors are needed for each shelf.



Corner connectors are recommended for use on traverses equal to or shorter than 48" (1220 mm), and are covered by U.S. Patent D624,764.



Wall Fastener

- Fastens a unit to a wall as a safety precaution.
- Screws not included.



Identification Tag

- Easily clips onto traverses to identify stored items.
- Made of PVC.
- Includes 12 HACCP labels.



4-Shelf Mobile Starter Units

- Mobile starter units ship complete in one box with 2 post kits, 8 mobile traverses, 32 mobile dovetails, shelf plates and 4 casters.
- Mobile traverses feature a 45° gusset for maximum cross-stabilization.
- Available with standard or premium casters.
- Mobile units are not designed to serve as transport carts.
- Mobile traverses and mobile dovetails are required to build a Mobile Elements Series Unit.



Donut Bumper

- Protects posts and casters.
- 5" (127 mm) Bumper.



Camshelving® Elements Series Configuration Details

- The following charts are provided to assist in developing a footprint for your storage area.
- They can also be used to help determine your actual shelf space.
- Shelf measurements are based on outside, or overall unit length & width including the posts.
- The overall length varies slightly when using an add-on, intermediate or corner unit.
- These variations are outlined below.

Shelf Spacing

Notches for dovetails are spaced every 4" (100 mm).

POST HEIGHT	NUMBER OF POSITIONS PER POST	POST HEIGHT WITH CASTER	NUMBER OF POSITIONS PER POST
Stationary		Mobile	
64" (1630 mm)	14	70" (1778 mm)	14
72" (1830 mm)	16	78" (1980 mm)	16
84" (2140 mm)	19		

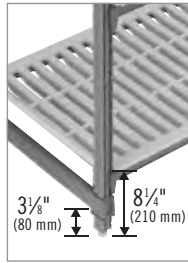

Easy To Adjust

Build Any Configuration and Fit Any Size Area

- Create a space efficient layout for any area.
- Assembles requiring only the use of a rubber mallet.
- Shelves can be adjusted in 4" (100 mm) increments without disassembling the entire unit.
- Two units can be connected together by sharing posts with shelves at alternating heights for maximum storage flexibility.
- Corner Connectors attach units to create a 90° angle or U-shape.

POST HEIGHT	DOVETAIL INCREMENT	NUMBER OF POSITIONS PER POST
Stationary		
64" (1630 mm)	4" (100 mm)	14
72" (1830 mm)	4" (100 mm)	16
84" (2140 mm)	4" (100 mm)	19
Mobile		
70" (1778 mm)	4" (100 mm)	14
78" (1980 mm)	4" (100 mm)	16

Shelving Consulting

Cambro provides a free consulting service to maximize your storage area. No cost or obligation.



1. Simply provide the dimensions of the storage space, number of shelves per unit, height of the posts, and any additional requirements you have.
2. Cambro will provide a recommended floor plan, 3-D view and product order list in Excel.
3. Your Cambro distributor or sales representative will contact you with pricing.
4. To contact the Camshelving Consulting Department, please call 1-714-230-4113, Fax 1-714-230-4199 or email mperez@cambro.com.

1.800.833.3003

Starter Unit

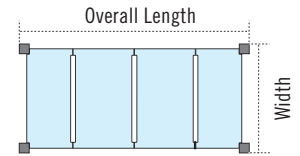

Add-on Unit

Shared posts between starter unit and add-on unit maximize space.

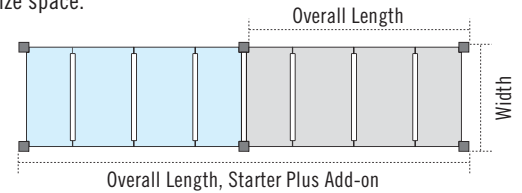

Corner Unit

Using one set of Corner Connectors per shelf.

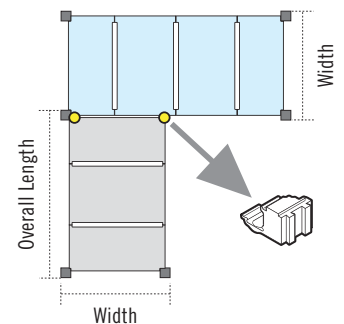

U-Shaped Unit

Requires two sets of corner connectors per shelf.

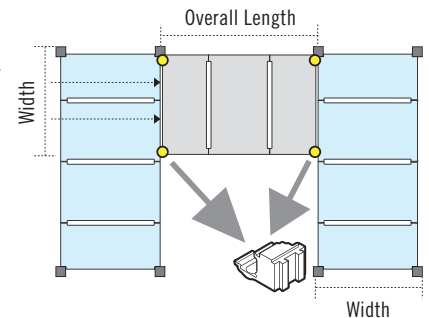

UNIT	CORNER UNIT OVERALL LENGTH	INTERMEDIATE UNIT OVERALL LENGTH
30" (760 mm)	29" (740 mm)	28" (715 mm)
36" (910 mm)	35" (890 mm)	34" (865 mm)
42" (1070 mm)	41" (1045 mm)	40" (1020 mm)
48" (1220 mm)	47" (1195 mm)	46" (1170 mm)

Corner Connectors are recommended for use on traverses 48" (1220 mm) or less.

UNIT	STARTER UNIT OVERALL LENGTH	ADD-ON UNIT OVERALL LENGTH	STARTER + ADD-ON UNIT OVERALL LENGTH
30" (760 mm)	30" (760 mm)	28 1/4" (720 mm)	58 1/4" (1480 mm)
36" (910 mm)	36" (910 mm)	34 1/4" (870 mm)	70 1/4" (1780 mm)
42" (1070 mm)	42" (1070 mm)	40 1/4" (1025 mm)	82 1/4" (2095 mm)
48" (1220 mm)	48" (1220 mm)	46 1/4" (1175 mm)	94 1/4" (2395 mm)
54" (1380 mm)	54" (1380 mm)	52 1/4" (1330 mm)	106 1/4" (2710 mm)
60" (1530 mm)	60" (1530 mm)	58 1/4" (1480 mm)	118 1/4" (3010 mm)
72" (1830 mm)	72" (1830 mm)	70 1/4" (1790 mm)	142 1/4" (3620 mm)
78" (1980 mm)	78" (1980 mm)	76 1/4" (1940 mm)	154 1/4" (3920 mm)

USA / Shelving



Stationary Post Kits

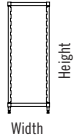

	WIDTH	14" 360 mm	18" 460 mm	21" 540 mm	24" 610 mm
HEIGHT 64" 1630 mm	CODE	EPK1464	EPK1864	EPK2164	EPK2464
	CASE LBS. (CUBE)	8.43 (0.46)	8.66 (0.46)	8.84 (0.46)	9.02 (0.46)
	CASE KG/CUBE M³	3,82 (0,01)	3,93 (0,01)	4,01 (0,01)	4,09 (0,01)
72" 1830 mm	CODE	EPK1472	EPK1872	EPK2172	EPK2472
	CASE LBS. (CUBE)	9.27 (0.52)	9.50 (0.52)	9.68 (0.52)	9.86 (0.52)
	CASE KG/CUBE M³	4,20 (0,01)	4,31 (0,01)	4,39 (0,01)	4,47 (0,01)
84" 2140 mm	CODE	EPK1484	EPK1884	EPK2184	EPK2484
	CASE LBS. (CUBE)	10.49 (0.61)	10.72 (0.61)	10.90 (0.61)	11.08 (0.61)
	CASE KG/CUBE M³	4,76 (0,02)	4,86 (0,02)	4,94 (0,02)	5,02 (0,02)

Includes 2 stationary posts with leveling feet installed, 1 top post connector, 1 bottom post connector, 8 post connector wedges in a bag and instructions.
Case Pack: 1 Color: Brushed Graphite (580).

Optional Accessories

Dunnage Stands

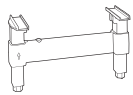

	WIDTH	14" 360 mm	18" 460 mm	21" 540 mm	24" 610 mm
HEIGHT 6½" 165 mm	CODE	EDS14	EDS18	EDS21	EDS24
	CASE LBS. (CUBE)	1.94 (0.18)	2.06 (0.22)	2.14 (0.26)	2.23 (0.30)
	CASE KG/CUBE M³	0,88 (0,001)	0,93 (0,006)	0,97 (0,007)	1,01 (0,008)

Case Pack: 1 Color: Brushed Graphite (580).

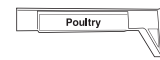
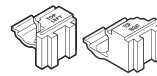
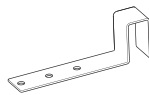

Accessories



DESCRIPTION	Seismic Foot	Wall Fastener	90° Left & Right Corner Connectors	ID Tag 6"	ID Tag 3"
CODE	CSEQ3	CSWF	ECC	CSID	CSID3
COLOR	Silver	Silver	Brushed Graphite (580)	White/Clear	White/Clear
CASE LBS. (CUBE)	1.43 (0.04)	4.08 (0.27)	0.70 (0.04)	0.82 (0.28)	0.58 (0.28)
CASE KG/CUBE M³	0,62 (0,011)	1,85 (0,006)	0,32 (0,001)	0,37 (0,01)	0,35 (0,01)
CASE PACK	4 each	4 each	1 set	12 each	12 each

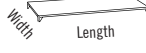

Solid Single Shelf Kits for Stationary Units

Camshelving®
Elements Series

 WIDTH Length	LENGTH				
	30" 	36"	42"	48"	
	760 mm	910 mm	1070 mm	1220 mm	
14" 360 mm	CODE	ESK1430S	ESK1436S	ESK1442S	ESK1448S
	CASE LBS. (CUBE)	6.68 (0.96)	8.23 (1.51)	9.77 (2.03)	10.50 (1.54)
	CASE KG/CUBE M ³	3,03 (0,03)	3,73 (0,04)	4,43 (0,06)	4,76 (0,04)
18" 460 mm	CODE	ESK1830S	ESK1836S	ESK1842S	ESK1848S
	CASE LBS. (CUBE)	7.55 (0.96)	9.23 (1.51)	11.09 (2.03)	11.78 (1.54)
	CASE KG/CUBE M ³	3,42 (0,03)	4,19 (0,04)	5,03 (0,06)	5,34 (0,04)
21" 540 mm	CODE	ESK2130S	ESK2136S	ESK2142S	ESK2148S
	CASE LBS. (CUBE)	8.38 (0.96)	10.65 (1.51)	12.61 (2.03)	13.70 (1.54)
	CASE KG/CUBE M ³	3,80 (0,03)	4,83 (0,04)	5,72 (0,06)	6,21 (0,04)
24" 610 mm	CODE	ESK2430S	ESK2436S	ESK2442S	ESK2448S
	CASE LBS. (CUBE)	9.13 (0.96)	11.40 (1.51)	13.50 (2.03)	14.90 (1.54)
	CASE KG/CUBE M ³	4,14 (0,03)	5,17 (0,04)	6,12 (0,06)	6,76 (0,04)
 WIDTH Length	LENGTH				78" 1980 mm CAMBRO Exclusive
	54"	60"	72"		
	1380 mm	1530 mm	1830 mm		
14" 360 mm	CODE	ESK1454S	ESK1460S	ESK1472S	ESK1478S
	CASE LBS. (CUBE)	12.15 (2.49)	13.66 (2.77)	15.79 (3.31)	16.73 (3.60)
	CASE KG/CUBE M ³	5,51 (0,07)	6,20 (0,08)	7,16 (0,09)	7,59 (0,10)
18" 460 mm	CODE	ESK1854S	ESK1860S	ESK1872S	ESK1878S
	CASE LBS. (CUBE)	13.74 (2.49)	15.58 (2.77)	17.98 (3.31)	18.92 (3.60)
	CASE KG/CUBE M ³	6,23 (0,07)	7,07 (0,08)	8,16 (0,09)	8,58 (0,10)
21" 540 mm	CODE	ESK2154S	ESK2160S	ESK2172S	ESK2178S
	CASE LBS. (CUBE)	15.77 (2.49)	17.70 (2.77)	20.61 (3.31)	21.55 (3.60)
	CASE KG/CUBE M ³	7,15 (0,07)	8,03 (0,08)	9,35 (0,09)	9,78 (0,10)
24" 610 mm	CODE	ESK2454S	ESK2460S	ESK2472S	ESK2478S
	CASE LBS. (CUBE)	17.10 (2.49)	19.16 (2.77)	22.51 (3.31)	23.45 (3.60)
	CASE KG/CUBE M ³	7,75 (0,07)	8,69 (0,08)	10,21 (0,09)	10,64 (0,10)

Includes solid shelf plates for 1 shelf, 2 stationary traverses, 1 bag of 8 stationary traverse dovetails (4 each A and B) and instructions.
Case Pack: 1 **Color:** Brushed Graphite (580).

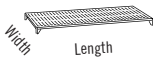
Vented Single and 4-Shelf Kits for Stationary Units

 WIDTH LENGTH 760 mm	LENGTH	30" 760 mm	36" 910 mm	42" 1070 mm	48" 1220 mm
	14" A 360 mm	CODE	ESK1430V	ESK1436V	ESK1442V
	CASE LBS. (CUBE)	6.41 (0.96)	7.88 (1.51)	9.36 (2.03)	9.97 (1.54)
	CASE KG/CUBE M³	2,91 (0,03)	3,57 (0,04)	4,24 (0,06)	4,52 (0,04)
18" A 460 mm	CODE	ESK1830V	ESK1836V	ESK1842V	ESK1848V
	CASE LBS. (CUBE)	7.14 (0.96)	8.75 (1.51)	10.46 (2.03)	11.12 (1.54)
	CASE KG/CUBE M³	3,24 (0,03)	3,97 (0,04)	4,75 (0,06)	5,05 (0,04)
21" A 540 mm	CODE	ESK2130V	ESK2136V	ESK2142V	ESK2148V
	CASE LBS. (CUBE)	7.65 (0.96)	9.74 (1.51)	11.64 (2.03)	12.46 (1.54)
	CASE KG/CUBE M³	3,47 (0,03)	4,42 (0,04)	5,28 (0,06)	5,65 (0,04)
24" A 610 mm	CODE	ESK2430V	ESK2436V	ESK2442V	ESK2448V
	CASE LBS. (CUBE)	8.48 (0.96)	10.55 (1.51)	12.58 (2.03)	13.75 (1.54)
	CASE KG/CUBE M³	3,85 (0,03)	4,79 (0,04)	5,70 (0,06)	6,24 (0,04)
18" B 460 mm	CODE	—	ESK1836V4	—	ESK1848V4
	CASE LBS. (CUBE)		32.10 (3.75)		41.04 (4.31)
	CASE KG/CUBE M³		14,57 (0,11)		18,63 (0,12)
24" B 610 mm	CODE	—	ESK2436V4	—	ESK2448V4
	CASE LBS. (CUBE)		39.31 (3.75)		51.53 (4.31)
	CASE KG/CUBE M³		17,85 (0,11)		23,39 (0,12)
 WIDTH LENGTH 1380 mm	LENGTH	54" 1380 mm	60" 1530 mm	72" 1830 mm	78" 1980 mm CAMBRO Exclusive
	14" A 360 mm	CODE	ESK1454V	ESK1460V	ESK1472V
	CASE LBS. (CUBE)	11.55 (2.49)	13.01 (2.77)	14.95 (3.31)	15.89 (3.60)
	CASE KG/CUBE M³	5,24 (0,07)	5,90 (0,08)	6,78 (0,09)	7,21 (0,10)
18" A 460 mm	CODE	ESK1854V	ESK1860V	ESK1872V	ESK1878V
	CASE LBS. (CUBE)	12.94 (2.49)	14.62 (2.77)	16.85 (3.31)	17.79 (3.60)
	CASE KG/CUBE M³	5,87 (0,07)	6,63 (0,08)	7,64 (0,09)	8,07 (0,10)
21" A 540 mm	CODE	ESK2154V	ESK2160V	ESK2172V	ESK2178V
	CASE LBS. (CUBE)	14.46 (2.49)	16.34 (2.77)	18.91 (3.31)	19.85 (3.60)
	CASE KG/CUBE M³	6,56 (0,07)	7,41 (0,08)	8,58 (0,09)	9,00 (0,10)
24" A 610 mm	CODE	ESK2454V	ESK2460V	ESK2472V	ESK2478V
	CASE LBS. (CUBE)	15.88 (2.49)	17.88 (2.77)	20.93 (3.31)	21.87 (3.60)
	CASE KG/CUBE M³	7,20 (0,07)	8,11 (0,08)	9,49 (0,09)	9,92 (0,10)
18" B 460 mm	CODE	—	ESK1860V4	—	—
	CASE LBS. (CUBE)		51.36 (5.84)		
	CASE KG/CUBE M³		23,32 (0,16)		
24" B 610 mm	CODE	—	ESK2460V4	—	—
	CASE LBS. (CUBE)		64.40 (5.84)		
	CASE KG/CUBE M³		29,24 (0,16)		

A - SINGLE SHELF - Includes vented shelf plates for 1 shelf, 2 stationary traverses, 1 bag of 8 stationary traverse dovetails (4 each A and B) and instructions.
 B - FOUR SHELVES - Includes vented shelf plates for 4 shelves, 8 stationary traverses, 1 bag of 32 stationary traverse dovetails (16 each A and B) and instructions.
 Case Pack: 1 Color: Brushed Graphite (580).

Vented 4-Shelf Stationary Starter Units 18" Width (460 mm)

Camshelving®
Elements Series

 HEIGHT 64" 1630 mm	LENGTH	36"	42"	48"	54"	60"
		910 mm	1070 mm	1220 mm	1380 mm	1530 mm
	CODE	ESU183664	ESU184264	ESU184864	ESU185464	ESU186064
	CASE LBS. (CUBE)	49.99 (5.92)	54.53 (5.92)	58.94 (5.92)	63.64 (5.92)	68.26 (5.92)
	CASE KG/CUBE M ³	22,68 (0,17)	24,74 (0,17)	26,74 (0,17)	28,87 (0,17)	30,96 (0,17)
72" 1830 mm	CODE	ESU183672	ESU184272	ESU184872	ESU185472	ESU186072
	CASE LBS. (CUBE)	51.27 (5.92)	55.81 (5.92)	60.22 (5.92)	64.92 (5.92)	69.54 (5.92)
	CASE KG/CUBE M ³	23,26 (0,17)	25,32 (0,17)	27,32 (0,17)	29,45 (0,17)	31,54 (0,17)

Includes 4 stationary posts with leveling feet installed - pre-assembled with post connectors and wedges,
1 bag of 32 stationary traverse dovetails (16 A and 16 B), vented shelf plates (for 4 shelves), 8 stationary traverses and instructions.
Case Pack: 1 Color: Brushed Graphite (580).

Vented 4-Shelf Stationary Starter Units 21" Width (540 mm)

 HEIGHT 64" 1630 mm	LENGTH	36"	42"	48"	54"	60"
		910 mm	1070 mm	1220 mm	1380 mm	1530 mm
	CODE	ESU213664	ESU214264	ESU214864	ESU215464	ESU216064
	CASE LBS. (CUBE)	54.94 (7.39)	60.23 (7.39)	65.28 (7.39)	70.74 (7.39)	76.11 (7.39)
	CASE KG/CUBE M ³	24,92 (0,21)	27,32 (0,21)	29,61 (0,21)	32,09 (0,21)	34,52 (0,21)
72" 1830 mm	CODE	ESU213672	ESU214272	ESU214872	ESU215472	ESU216072
	CASE LBS. (CUBE)	56.22 (7.39)	61.51 (7.39)	66.57 (7.39)	72.02 (7.39)	77.39 (7.39)
	CASE KG/CUBE M ³	25,50 (0,21)	27,90 (0,21)	30,20 (0,21)	32,67 (0,21)	35,10 (0,21)

Includes 4 stationary posts with leveling feet installed - pre-assembled with post connectors and wedges,
1 bag of 32 stationary traverse dovetails (16 A and 16 B), vented shelf plates (for 4 shelves), 8 stationary traverses and instructions.
Case Pack: 1 Color: Brushed Graphite (580).

Vented 4-Shelf Stationary Starter Units 24" Width (610 mm)

 HEIGHT 64" 1630 mm	LENGTH	36"	42"	48"	54"	60"
		910 mm	1070 mm	1220 mm	1380 mm	1530 mm
	CODE	ESU243664	ESU244264	ESU244864	ESU245464	ESU246064
	CASE LBS. (CUBE)	59.50 (8.49)	61.66 (8.49)	71.72 (8.49)	77.70 (8.49)	83.59 (8.49)
	CASE KG/CUBE M ³	26,99 (0,24)	27,97 (0,24)	32,53 (0,24)	35,24 (0,24)	37,92 (0,24)
72" 1830 mm	CODE	ESU243672	ESU244272	ESU244872	ESU245472	ESU246072
	CASE LBS. (CUBE)	60.78 (8.49)	66.59 (8.49)	72.99 (8.49)	79.98 (8.49)	84.87 (8.49)
	CASE KG/CUBE M ³	27,57 (0,24)	30,21 (0,24)	33,11 (0,24)	35,82 (0,24)	38,50 (0,24)
* 84" 2140 mm	CODE	ESU243684PKG	ESU244284PKG	ESU244884PKG	ESU245484PKG	ESU246084PKG
	CASE LBS. (CUBE)	61.46 (14.30)	67.27 (15.57)	73.68 (12.57)	80.66 (14.59)	86.55 (15.14)
	CASE KG/CUBE M ³	27,88 (0,14)	30,51 (0,17)	33,42 (0,16)	36,58 (0,2)	39,26 (0,2)

Includes 4 stationary posts with leveling feet installed - pre-assembled with post connectors and wedges,
1 bag of 32 stationary traverse dovetails (16 A and 16 B), vented shelf plates (for 4 shelves), 8 stationary traverses and instructions.
Case Pack: 1 Color: Brushed Graphite (580).

* Due to the size of 84" (2140 mm) shelving, starter units ship in 3 cartons.

Vented 4-Shelf Stationary Add-On Units 18" Width (460 mm)

Camshelving®
Elements Series



HEIGHT	LENGTH	36"	42"	48"	54"	60"
		910 mm	1070 mm	1220 mm	1380 mm	1530 mm
64" 1630 mm	CODE	EA183664	EA184264	EA184864	EA185464	EA186064
	CASE LBS. (CUBE)	42.35 (5.92)	46.88 (5.92)	51.30 (5.92)	55.99 (5.92)	60.61 (5.92)
	CASE KG/CUBE M³	19,21 (0,17)	21,27 (0,17)	23,27 (0,17)	25,40 (0,17)	27,49 (0,17)
72" 1830 mm	CODE	EA183672	EA184272	EA184872	EA185472	EA186072
	CASE LBS. (CUBE)	42.99 (5.92)	47.53 (5.92)	51.94 (5.92)	56.64 (5.92)	61.25 (5.92)
	CASE KG/CUBE M³	19,50 (0,17)	21,56 (0,17)	23,56 (0,17)	25,69 (0,17)	27,78 (0,17)

Includes 2 stationary posts with leveling feet installed - pre-assembled with post connectors and wedges,
1 bag of 32 stationary traverse dovetails (16 A and 16 B), vented shelf plates (for 4 shelves), 8 stationary traverses and instructions.
Case Pack: 1 Color: Brushed Graphite (580).

Vented 4-Shelf Stationary Add-On Units 21" Width (540 mm)



HEIGHT	LENGTH	36"	42"	48"	54"	60"
		910 mm	1070 mm	1220 mm	1380 mm	1530 mm
64" 1630 mm	CODE	EA213664	EA214264	EA214864	EA215464	EA216064
	CASE LBS. (CUBE)	47.13 (7.39)	52.41 (7.39)	57.47 (7.39)	62.92 (7.39)	68.29 (7.39)
	CASE KG/CUBE M³	21,38 (0,21)	23,78 (0,21)	26,07 (0,21)	28,54 (0,21)	30,98 (0,21)
72" 1830 mm	CODE	EA213672	EA214272	EA214872	EA215472	EA216072
	CASE LBS. (CUBE)	47.77 (7.39)	53.05 (7.39)	58.11 (7.39)	63.56 (7.39)	68.93 (7.39)
	CASE KG/CUBE M³	21,67 (0,21)	24,07 (0,21)	26,36 (0,21)	28,83 (0,21)	31,27 (0,21)

Includes 2 stationary posts with leveling feet installed - pre-assembled with post connectors and wedges,
1 bag of 32 stationary traverse dovetails (16 A and 16 B), vented shelf plates (for 4 shelves), 8 stationary traverses and instructions.
Case Pack: 1 Color: Brushed Graphite (580).

Vented 4-Shelf Stationary Add-On Units 24" Width (610 mm)



HEIGHT	LENGTH	36"	42"	48"	54"	60"
		910 mm	1070 mm	1220 mm	1380 mm	1530 mm
64" 1630 mm	CODE	EA243664	EA244264	EA244864	EA245464	EA246064
	CASE LBS. (CUBE)	51.50 (8.49)	57.32 (8.49)	63.72 (8.49)	69.70 (8.49)	73.42 (8.49)
	CASE KG/CUBE M³	23,36 (0,24)	25,99 (0,24)	28,91 (0,24)	31,62 (0,24)	34,29 (0,24)
72" 1830 mm	CODE	EA243672	EA244272	EA244872	EA245472	EA246072
	CASE LBS. (CUBE)	52.14 (8.49)	57.96 (8.49)	64.36 (8.49)	70.34 (8.49)	74.26 (8.49)
	CASE KG/CUBE M³	23,65 (0,24)	26,29 (0,24)	29,20 (0,24)	31,91 (0,24)	34,58 (0,24)
*84" 2140 mm	CODE	EA243684PKG	EA244284PKG	EA244884PKG	EA245484PKG	EA246084PKG
	CASE LBS. (CUBE)	50.38 (11.62)	56.20 (12.88)	62.60 (10.05)	69.58 (11.91)	75.48 (11.82)
	CASE KG/CUBE M³	22,85 (0,12)	25,49 (0,16)	28,40 (0,14)	31,56 (0,18)	34,24 (0,18)

Includes 2 stationary posts with leveling feet installed - pre-assembled with post connectors and wedges,
1 bag of 32 stationary traverse dovetails (16 A and 16 B), vented shelf plates (for 4 shelves), 8 stationary traverses, instructions
Case Pack: 1 Color: Brushed Graphite (580).

* Due to the size of 84" (2140 mm) shelving, add-on units ship in 2 cartons.

Mobile Post Kits

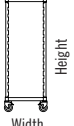

	WIDTH	18" 460 mm	21" 540 mm	24" 610 mm
HEIGHT 70" 1778 mm	CODE	EMPK1870	EMPK2170	EMPK2470
	CASE LBS. (CUBE)	8.66 (0.46)	8.84 (0.46)	9.02 (0.46)
	CASE KG/CUBE M ³	3,93 (0,01)	4,01 (0,01)	4,09 (0,01)
78" 1980 mm	CODE	EMPK1878	EMPK2178	EMPK2478
	CASE LBS. (CUBE)	9.50 (0.52)	9.68 (0.52)	9.86 (0.52)
	CASE KG/CUBE M ³	4,31 (0,01)	4,39 (0,01)	4,47 (0,01)

Includes 2 mobile posts without leveling feet installed, 1 top post connector, 1 bottom post connector, 8 post connector wedges in a bag and instructions. Casters are not included and must be ordered separately. **Note:** Height in chart includes casters.

Case Pack: 1 **Color:** Brushed Graphite (580).

Solid Shelf Kits for Mobile Units

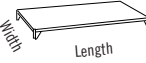

	LENGTH	36" 910 mm	42" 1070 mm	48" 1220 mm	54" 1380 mm	60" 1530 mm
WIDTH 18" 460 mm	CODE	EMSK1836S	EMSK1842S	EMSK1848S	EMSK1854S	EMSK1860S
	CASE LBS. (CUBE)	9.69 (1.51)	11.55 (2.03)	12.25 (1.54)	13.99 (2.63)	15.85 (2.91)
	CASE KG/CUBE M ³	4,40 (0,04)	5,24 (0,06)	5,55 (0,04)	6,35 (0,07)	7,12 (0,08)
21" 540 mm	CODE	EMSK2136S	EMSK2142S	EMSK2148S	EMSK2154S	EMSK2160S
	CASE LBS. (CUBE)	11.11 (1.51)	13.08 (2.03)	14.16 (1.54)	16.01 (2.63)	17.98 (2.91)
	CASE KG/CUBE M ³	5,04 (0,04)	5,93 (0,06)	6,24 (0,04)	7,26 (0,07)	8,16 (0,08)
24" 610 mm	CODE	EMSK2436S	EMSK2442S	EMSK2448S	EMSK2454S	EMSK2460S
	CASE LBS. (CUBE)	11.87 (1.51)	13.96 (2.03)	15.36 (1.54)	17.34 (2.63)	19.43 (2.91)
	CASE KG/CUBE M ³	5,38 (0,04)	6,33 (0,06)	6,97 (0,04)	7,86 (0,07)	8,81 (0,08)

Includes solid shelf plates for 1 shelf, 2 mobile traverses, 1 bag of 8 mobile traverse dovetails (4 each A and B) and instructions.

Case Pack: 1 **Color:** Brushed Graphite (580).

Vented Shelf Kits for Mobile Units

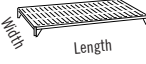

	LENGTH	36" 910 mm	42" 1070 mm	48" 1220 mm	54" 1380 mm	60" 1530 mm
WIDTH 18" 460 mm	CODE	EMSK1836V	EMSK1842V	EMSK1848V	EMSK1854V	EMSK1860V
	CASE LBS. (CUBE)	9.22 (1.51)	10.93 (2.03)	11.59 (1.54)	13.18 (2.63)	14.89 (2.91)
	CASE KG/CUBE M ³	4,18 (0,04)	4,96 (0,06)	5,26 (0,04)	5,97 (0,07)	6,75 (0,08)
21" 540 mm	CODE	EMSK2136V	EMSK2142V	EMSK2148V	EMSK2154V	EMSK2160V
	CASE LBS. (CUBE)	10.20 (1.51)	12.10 (2.03)	12.93 (1.54)	14.71 (2.63)	16.61 (2.91)
	CASE KG/CUBE M ³	4,63 (0,04)	5,49 (0,06)	5,86 (0,04)	6,67 (0,07)	7,53 (0,08)
24" 610 mm	CODE	EMSK2436V	EMSK2442V	EMSK2448V	EMSK2454V	EMSK2460V
	CASE LBS. (CUBE)	11.02 (1.51)	13.05 (2.03)	14.21 (1.54)	16.12 (2.63)	18.15 (2.91)
	CASE KG/CUBE M ³	4,99 (0,04)	5,92 (0,06)	6,45 (0,04)	7,31 (0,07)	8,23 (0,08)

Includes vented shelf plates for 1 shelf, 2 mobile traverses, 1 bag of 8 mobile traverse dovetails (4 each A and B) and instructions.

Case Pack: 1 **Color:** Brushed Graphite (580).

Vented 4-Shelf Mobile Starter Units 18" Width (460 mm)

Camshelving®
Elements Series



HEIGHT	LENGTH	36"	36"	42"	42"	48"	48"
		910 mm PREMIUM	910 mm STANDARD	1070 mm PREMIUM	1070 mm STANDARD	1220 mm PREMIUM	1220 mm STANDARD
70" 1778 mm	CODE	EMU183670P	EMU183670	EMU184270P	EMU184270	EMU184870P	EMU184870
	CASE LBS. (CUBE)	60.13 (5.92)	60.13 (5.92)	64.67 (5.92)	64.67 (5.92)	69.08 (5.92)	69.08 (5.92)
	CASE KG/CUBE M³	33,48 (0,17)	33,48 (0,17)	36,52 (0,17)	36,52 (0,17)	39,61 (0,17)	39,61 (0,17)
78" 1980 mm	CODE	EMU183678P	EMU183678	EMU184278P	EMU184278	EMU184878P	EMU184878
	CASE LBS. (CUBE)	61.41 (5.92)	61.41 (5.92)	65.95 (5.92)	65.95 (5.92)	70.36 (5.92)	70.36 (5.92)
	CASE KG/CUBE M³	34,06 (0,17)	34,06 (0,17)	37,09 (0,17)	37,09 (0,17)	40,19 (0,17)	40,19 (0,17)

Premium - Includes 4 mobile posts without leveling feet, post connectors and wedges installed, 1 bag of 32 mobile traverse dovetails (16 each A and B), vented shelf plates, 8 mobile traverses, 4 premium casters and instructions.

Standard - Includes 4 mobile posts without leveling feet, post connectors and wedges installed, 1 bag of 32 mobile traverse dovetails (16 each A and B), vented shelf plates, 8 mobile traverses, 4 standard casters and instructions.

Case Pack: 1 **Color:** Brushed Graphite (580).

Vented 4-Shelf Mobile Starter Units 21" Width (540 mm)



HEIGHT	LENGTH	36"	36"	42"	42"	48"	48"
		910 mm PREMIUM	910 mm STANDARD	1070 mm PREMIUM	1070 mm STANDARD	1220 mm PREMIUM	1220 mm STANDARD
70" 1778 mm	CODE	EMU213670P	EMU213670	EMU214270P	EMU214270	EMU214870P	EMU214870
	CASE LBS. (CUBE)	65.08 (7.39)	65.08 (7.39)	70.37 (7.39)	70.37 (7.39)	75.43 (7.39)	75.43 (7.39)
	CASE KG/CUBE M³	35,72 (0,21)	35,72 (0,21)	39,10 (0,21)	39,10 (0,21)	42,49 (0,21)	44,82 (0,21)
78" 1980 mm	CODE	EMU213678P	EMU213678	EMU214278P	EMU214278	EMU214878P	EMU214878
	CASE LBS. (CUBE)	66.36 (7.39)	66.36 (7.39)	71.65 (7.39)	71.65 (7.39)	76.71 (7.39)	76.71 (7.39)
	CASE KG/CUBE M³	36,31 (0,21)	36,31 (0,21)	39,68 (0,21)	39,68 (0,21)	43,07 (0,21)	45,40 (0,21)

Premium - Includes 4 mobile posts without leveling feet, post connectors and wedges installed, 1 bag of 32 mobile traverse dovetails (16 each A and B), vented shelf plates, 8 mobile traverses, 4 premium casters and instructions.

Standard - Includes 4 mobile posts without leveling feet, post connectors and wedges installed, 1 bag of 32 mobile traverse dovetails (16 each A and B), vented shelf plates, 8 mobile traverses, 4 standard casters and instructions.

Case Pack: 1 **Color:** Brushed Graphite (580).

Vented 4-Shelf Mobile Starter Units 24" Width (610 mm)



HEIGHT	LENGTH	36"	36"	42"	42"	48"	48"
		910 mm PREMIUM	910 mm STANDARD	1070 mm PREMIUM	1070 mm STANDARD	1220 mm PREMIUM	1220 mm STANDARD
70" 1778 mm	CODE	EMU243670P	EMU243670	EMU244270P	EMU244270	EMU244870P	EMU244870
	CASE LBS. (CUBE)	69.64 (8.49)	69.64 (8.49)	75.45 (8.49)	75.45 (8.49)	81.86 (8.49)	81.86 (8.49)
	CASE KG/CUBE M³	37,79 (0,24)	37,79 (0,24)	41,41 (0,24)	41,41 (0,24)	45,40 (0,24)	45,40 (0,24)
78" 1980 mm	CODE	EMU243678P	EMU243678	EMU244278P	EMU244278	EMU244878P	EMU244878
	CASE LBS. (CUBE)	70.92 (8.49)	70.92 (8.49)	76.71 (8.49)	76.71 (8.49)	83.14 (8.49)	83.14 (8.49)
	CASE KG/CUBE M³	38,37 (0,24)	38,37 (0,24)	41,99 (0,24)	41,99 (0,24)	45,98 (0,24)	45,98 (0,24)

Premium - Includes 4 mobile posts without leveling feet, connectors and wedges installed, 1 bag of 32 mobile traverse dovetails (16 each A and B), vented shelf plates, 8 mobile traverses, 4 premium casters, instructions.

Standard - Includes 4 posts without leveling feet, connectors and wedges installed, 1 bags of 32 mobile traverse dovetails (16 each A and B), shelf plates, 8 mobile traverses, 4 standard casters, instructions

Case Pack: 1 **Color:** Brushed Graphite (580).

Casters and Donut Bumper

Camshelving®
Elements Series



DIAMETER	5" 127 mm PREMIUM	5" 127 mm PREMIUM	5" 127 mm STANDARD	5" 127 mm STANDARD	5" 127 mm
CODE	EMSCBP	EMSCP	EMSCB	EMSC	CSHDDB
DESCRIPTION	Swivel with Brake	Swivel No Brake	Swivel with Brake	Swivel No Brake	Donut Bumper
CASE LBS. (CUBE)	4.75 (0.16)	4.35 (0.16)	4.75 (0.16)	4.35 (0.16)	2.01 (0.05)
CASE KG/CUBE M³	2,16 (0,005)	1,97 (0,005)	2,16 (0,005)	1,97 (0,005)	0,91 (0,001)
CASE PACK	2	2	2	2	4

PREMIUM CASTERS - Stainless steel with a non-marking polyurethane wheel. Recommended for use in wet areas or in walk-in refrigerators and freezers.
STANDARD CASTERS - Zinc plated with a non-marking polyurethane wheel. Recommended for use in dry storage areas.

Divider Bar for Elements Series

- Creates a custom storage unit that can accommodate a variety of storage products and sizes on a single unit.
- Divider bars fit on 24" (610 mm) wide Elements Series units and hold up to 200 lbs. (91 Kg) per shelf.



CODE	DESCRIPTION	CASE LBS. (CUBE)	CASE KG/ CUBE M³
EDBA	Divider Bar Angled	1.91 (0.10)	0,87 (0,003)
EDBS	Divider Bar Straight	1.91 (0.10)	0,87 (0,003)

Case Pack: 4 Color: Speckled Gray (480).

Dunnage Racks



S-Series Dunnage Racks

- Keep frozen, cold or dry inventory 12" (30,5 cm) safely off the floor.
- One piece construction and sturdy legs provide strength and stability.
- Heavy duty polypropylene is safe to -36°F (-38°C), and will not rust, corrode or bend.
- Choose slotted tops for maximum air circulation around perishable products.
- Solid tops catch spills for easy clean up.

Colors: Dark Brown (131),
Speckled Gray (480).



CODE	EXTERIOR DIMENSIONS H x D x W	LOAD CAPACITY	CASE LBS. (CUBE)
Solid Top			
DRS30	12" x 21" x 30"	1500 lbs.	22.05 (4.75)
DRS36	12" x 21" x 36"	1500 lbs.	26 (5.72)
DRS48	12" x 21" x 48"	3000 lbs.	35.10 (7.41)
DRS60	12" x 21" x 60"	3000 lbs.	44.66 (9.53)
Slotted Top			
DRS300	12" x 21" x 30"	1500 lbs.	20 (4.78)
DRS360	12" x 21" x 36"	1500 lbs.	25 (5.72)
DRS480	12" x 21" x 48"	3000 lbs.	34.07 (7.45)
DRS600	12" x 21" x 60"	3000 lbs.	42.37 (9.36)

Case Pack: 1 InStock Color: Speckled Gray (480).

Camlink®

Camlink connectors securely lock dunnage racks together for greater stability.



Color: Black (110).

CODE	CASE PACK
DRLNK	6

Camlink is covered by U.S. Patent D 397,289.

Camlink fits all sizes and styles. One free Camlink supplied with every Dunnage Rack.

